

Presentation

A4/2

Power bases, control modules, connectors - TeSys U

Type of product

Range

Page

Standard power base,
basic control functionalities
Direct and reversing

Up to 15 kW

A4/10

Advance power base, control, alarm
and communication possibilities
Direct and reversing

Up to 15 kW

A4/12



Communication components - TeSys U

Parallel type cabling system
Principle and components

A4/18

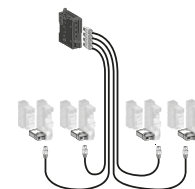

Bus type cabling systems
Principle, panorama and components

A4/23

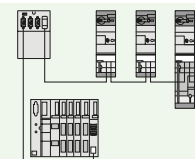

LUF communication gateway

A4/32



Accessories - TeSys U

Short circuit current limiter

A4/33



Handles and accessories
for rotary control

A4/34

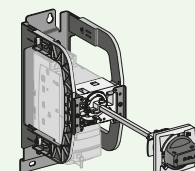

Handles and accessories
for integration into a MCC drawer

A4/35

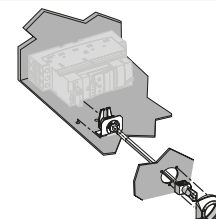

Technical Data for Designers

A4/37

From traditional solution to ...

TeSys U

Motor circuit breaker:
TeSys GV2 L



Magnetic protection
> short-circuit protection

Contactor:
TeSys D



Control
> Start /Stop

Status monitoring
> signaling
> alarm monitoring

Protection relay:
TeSys LRD

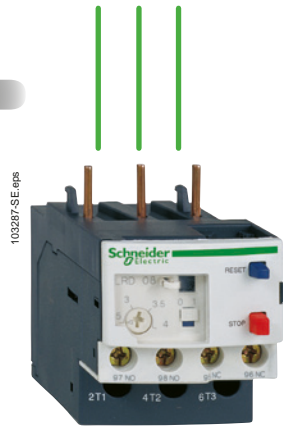

Thermal protection
> overload

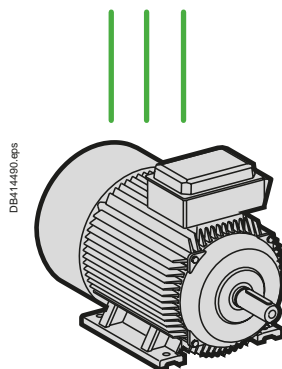

...TeSys U starter-controller



DB402785.eps

DB414480.eps

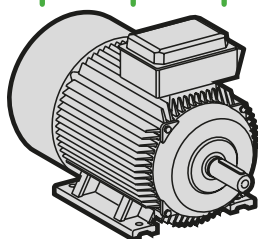

TeSys U starter-controller

> All basic or advanced protection and control functions in one block

and more...

- > Overload indication and alarm
- > Status report, remote control via communication bus



TeSys U

can be used in

80 %

of motor protection and control applications.

TeSys U



TeSys U

1 All in one

- Optimising space in enclosures.
- Total coordination (No contact welding on short circuit).
- Reduces installation times.

2 Simplicity of choice

- Controlled power.
- Protection functions ensured.
- Signaling functions, communication with PLC ensured.

3 Universal mounting

- On DIN rail or grid.

4 Conventional projet design

- Conventional control scheme with start , stop push buttons.

5 Electrically simple

Basic scheme of a TeSys U starter-controller

- Protection and power control functions acting on a single set of contact (QF1).
- The control unit (CU) monitors the voltage and current. In case of fault, it releases the coil, causing tripping.
- The coil is controlled by manual orders from an operator. Automatic control from a PLC is achieved with other diagrams.

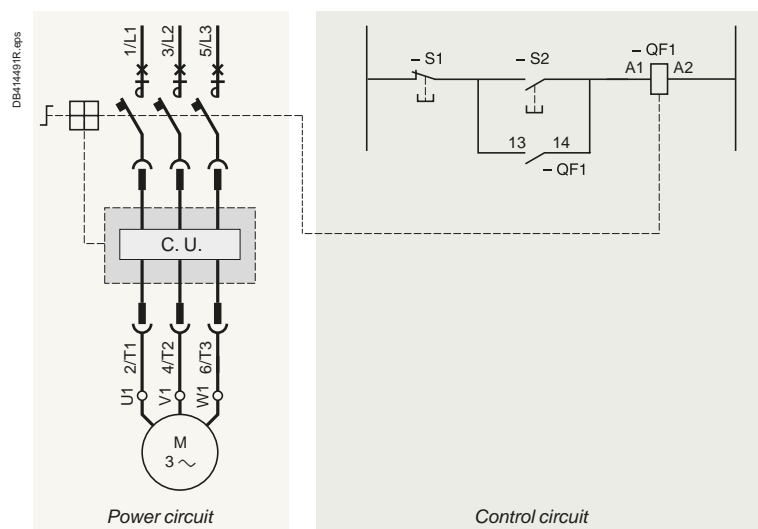

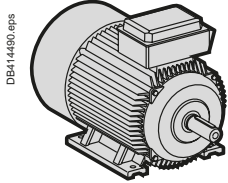

Motor up to

- 7.5 kW / 1-phase 230 V / 50-60 Hz.
- 15 kW / 3-phase 400-440 V / 50-60 Hz.
- 15 kW / 3-phase 500 V / 50-60 Hz.
- 18.5 kW / 3-phase 690 V / 50-60 Hz.
- Non-reversing or reversing.

Short-circuit protection

- I_{sc}:
 - 50 kA at ≤ 400 V
 - 10 kA at 500 V
 - 4 kA at 690 V.
- Up to 690 V AC.

Overload protection

- From 0.15 to 32 A, 6 setting ranges (tripping 14.2 x I setting).
- Test button.
- Adjustment lock.
- Coil choice: 24 V, 48...72 V, 110...240 V DC/AC.

3 power contacts

- For non-reversing (reversing with reverser block).
- I_{max}, for 12 A power base (direct - reversing):
 - 12 A at up to 500 V / 50 Hz
 - 9 A > 500 V, up to 690 V.
- I_{max}, for 32 A power base (direct - reversing):
 - 32 A at up to 500 V / 50 Hz
 - 21 A > 500 V, up to 690 V.

1 NO contact

1 NC contact

- 5 A / max. 690 V AC or 250 V CC.

Other monitoring contacts

- 5 A / max. 690 V AC or 250 V DC.

Communication modules

- Modbus,
- Ethernet,
- CANopen,
- DeviceNet,
- Advantys stb,
- Profibus DP,
- Beckhoff,
- AS-interface.

Dimensions

■ Base:

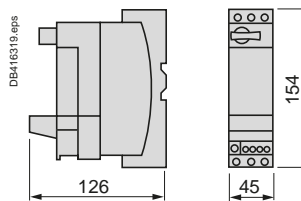

■ Base + reverser block:

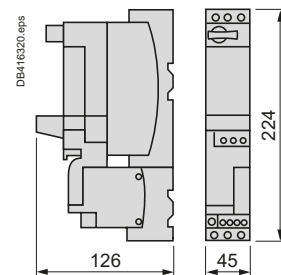

The modularity principle

DB-14483.eps

TeSys U

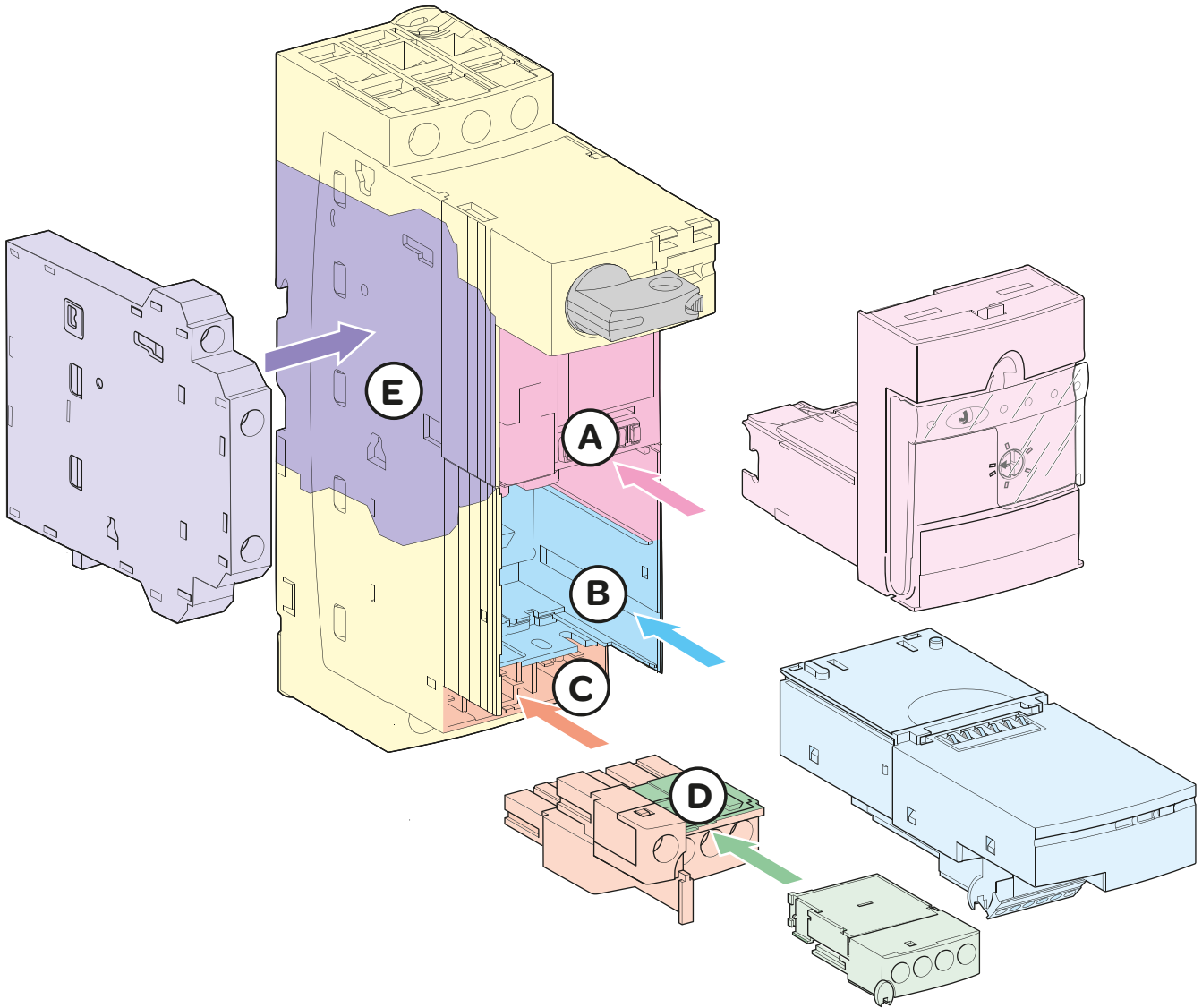

- Power base
- A Cavity for control unit
- B Cavity for auxiliary module
- C Cavity for control terminal block
- D Cavity for additional contact block or shutter
- E Space for additional block fastening

Power Base

This is the basic constituent of the motor starter, it is composed of the power contacts, the control coil, the opening / closing mechanism of the protection device and the control pad.

Additional lateral block

Composed of the protection device signaling contacts.

Control unit

Composed of the power base management processor and setting knobs.

Auxiliary module

Depending on its type, it integrates load status contacts or a communication processor or an alarm processor.

Control terminal block

It is composed of two terminals "coil control", 1 NO auxiliary contact, 1 NC auxiliary contact. It can be eventually connected to an auxiliary communication module via a dedicated cable.

Additional block

It includes protection device additional signaling contacts. By default, this is a simple shutter.

Components overview

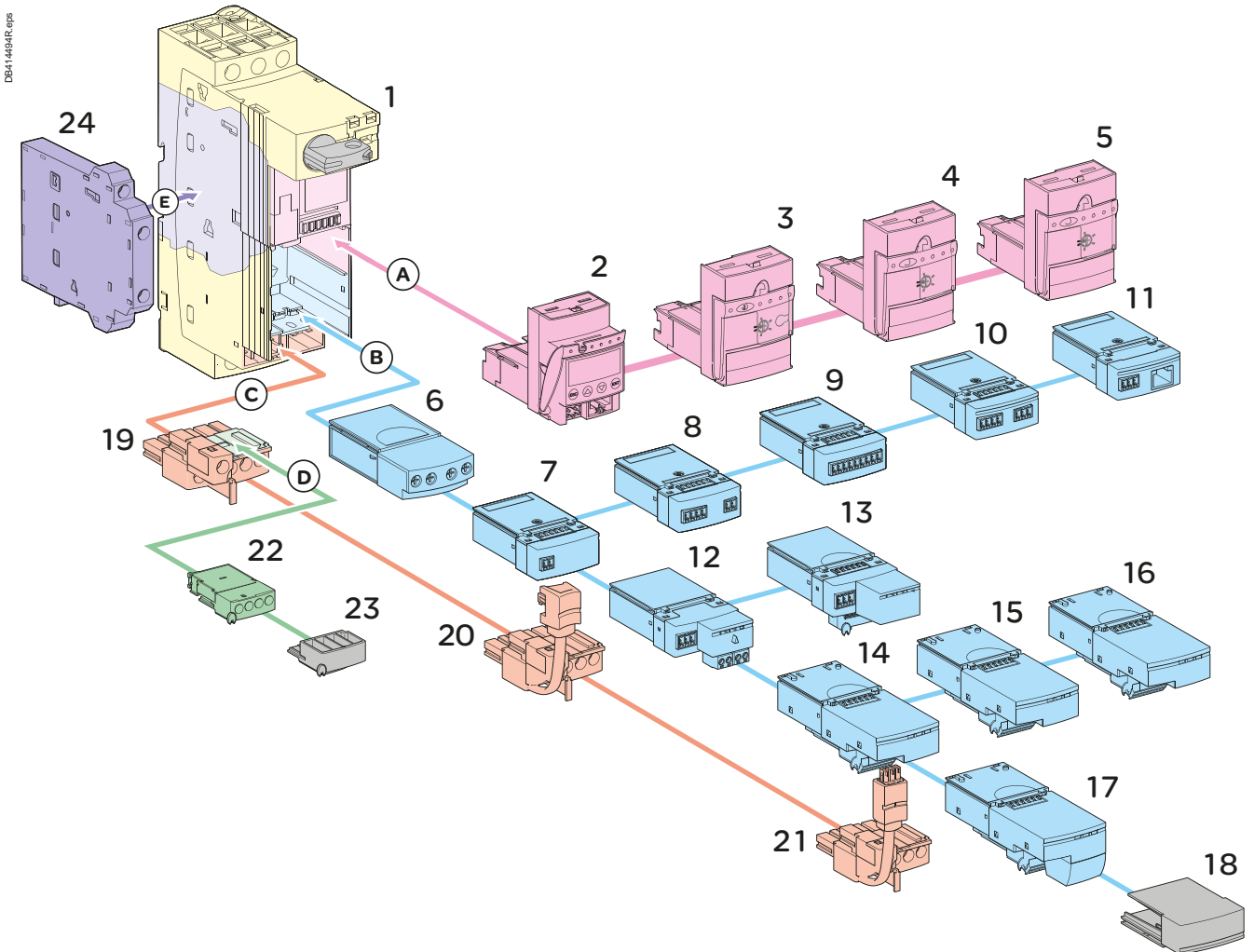

TeSys U

Power base

- 1- LUB**
Non reversing power base - 1 rotation direction

Control units

- 2- LUCM**
Multifunctional control unit
- 3- LUCB/LUCC/LUCD**
Advanced control units
- 4- LUCA**
Standard control unit
- 5- LUCL**
Magnetic protection control unit

Auxiliary module

- 6- LUFN**
Auxiliary contacts module

Load monitoring auxiliary modules

- 7- LUFW10**
Overload alarm module
- 8- LUFDH11**
Overload alarm module with manual reset
- 9- LUFDA01/LUFAD10**
Overload alarm module with automatic reset/remote reset
- 10- LUFV2**
Motor load indication module

Communication auxiliary modules

- 11- LUFC00**
Telefast parallel liaison module, with RJ45 connector
- 12- ASILUFC5/ASILUFC51**
AS-Interface c. m.
- 13- LULC031/LULC033**
Modbus c. m.
- 14- LULC07** Profibus DP c. m.
- 15- LULC08** CANopen c. m.
- 16- LULC09** DeviceNET c. m.
- 17- LULC15** Advantys STB c. m.

Shutters

- 18- LU9C 1**
Shutter for module cavity
- 23- Shutter** for contacts additional block cavity

Control terminal blocks

- 19- LU9BN11**
Terminal block for imbedded auxiliary contacts
- 20- LU9BN11C**
Coil terminal block with its connecting cable
- 21- LU9BN11L**
Coil terminal block with its connecting cable

Additional contacts blocks

- 22- LUA1**
Additional contacts
- 24- LUA8**
side-mounting additional contacts

Presentation

Control units and modules

On/off control, 2 directions of rotation, vertical mounting

Additional components overview

DB1445R.eps

TeSys U

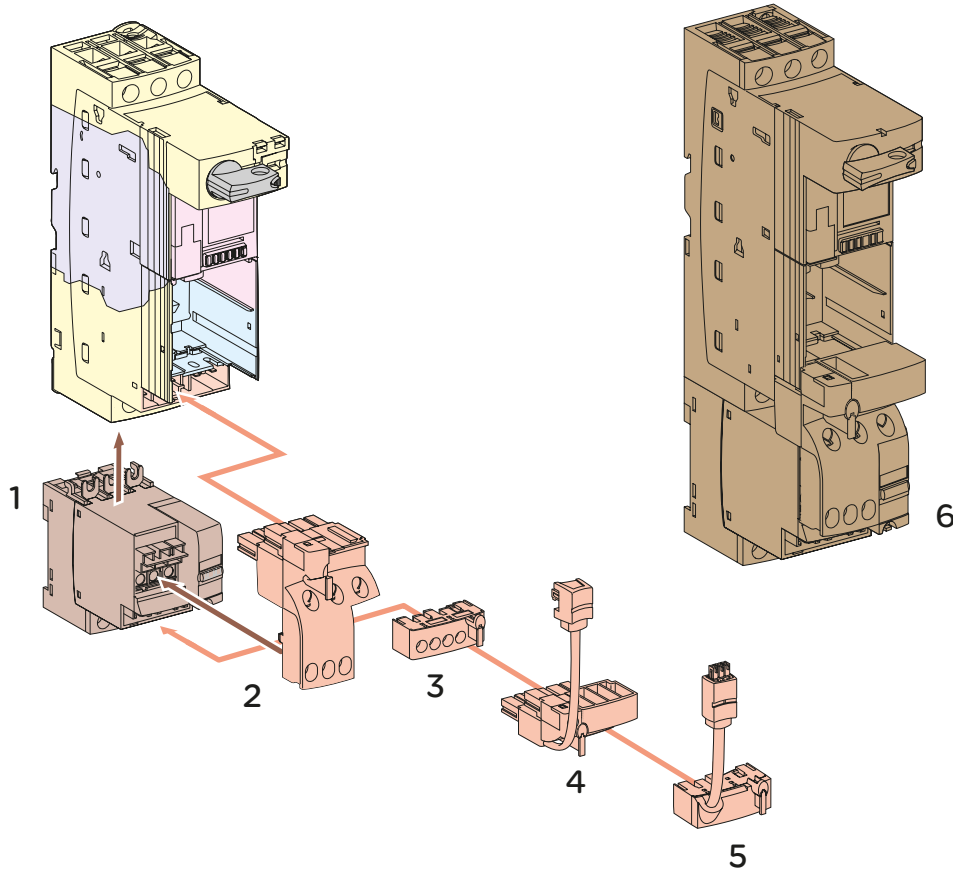

Reverser block

1- LU2M B0
vertical-mounting reverser block

Evolving reversing power base

6- Pre-assembled reversing power base **LU2B12**

Control terminal blocks

- 2- LU9MR1C**
Base/block assembling connector, with terminal block for imbedded auxiliary contacts
- 3- LU9M1**
Coil terminal block for wired control
- 4- LU9MRC**
Coil terminal block with its connecting cable for communicating control (only compatible with a selection of com. modules).
- 5- LU9MRL**
Coil terminal block with its connecting cable for communicating control (only compatible with a selection of com. modules).

Presentation

Control units and modules

On/off control, 2 directions of rotation, side-mounting

Additional components overview

DB114497.eps

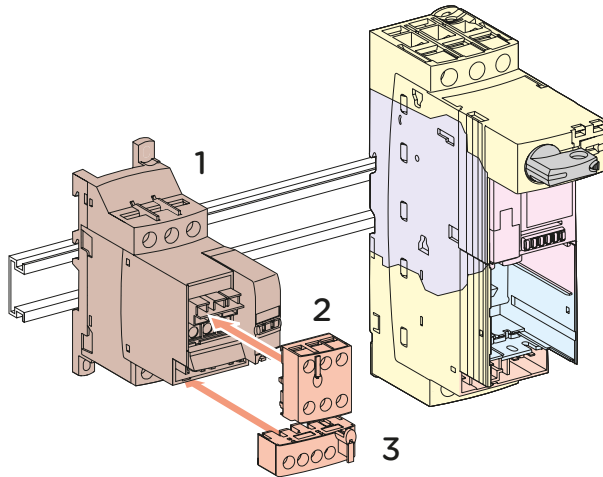

TeSys U

Reverser block





- 1- LU6M B0●●
Side-mounting reverser block

Terminal blocks for electrical remote control

- 2- LU9MR1
Terminal block for 2 direction control (pulse or maintained control)
- 3- LU9M1
Terminal block for power base coil interlocking.
With direction of rotation monitoring contacts

- Rotation control: 1 direction - 2 directions.
- Protection: overload + short circuits + main power fault.
- Monitoring: by dry contacts.

1- Selection of the standard power base

				
Rating / Ue AC	12 A / 400 V 12 A / 500 V 9A / 690 V		32 A / 400 V 23 A / 500 V 21 A / 690 V	
Cial. ref.: replace dots by the coil code	1 direction Standard power base LUB12	2 directions Standard reversing power base LU2B12●●	1 direction Standard power base LUB32	2 directions Standard reversing power base LU2B32●●

2- Selection of the control unit

Maximum standardized power ratings of 3 phases motors 50/60 Hz

400/440 V kW	500 V kW	600 V kW	Setting range A	Lip_in mounting on the power base - Rating A	Protection type	Thermal + magnetic LUCA	Magnetic LUCL
0.09	-	-	0.15...0,6	12 and 32	LUCAX6●●	LUCLX6●●	
0.25	-	-	0.35...1,4	12 and 32	LUA1X●●	LUCL1X●●	
1.5	2.2	3	1.25...5	12 and 32	LUA05●●	LUCL05●●	
5.5	5.5	9	3...12	12 and 32	LUA12●●	LUCL12●●	
7.5	9	15	4.5...18	32	LUA18●●	LUCL18●●	
15	15	18.5	8...32	32	LUA32●●	LUCL32●●	

Cial. ref. of the control unit: dots to be replaced by the coil code (see below).

Coil voltage (V)	24~	24~	48...72 ~ and 48~	110...220 ~ and 110...240~
Coil code	BL	B	ES	FU

3- Selection of the modules (1) and signaling blocks (optional)

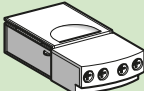
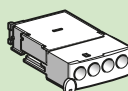
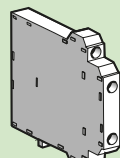
	Auxiliary signaling contacts module	Function	Indicates the ON/OFF running status of the motor, whatever the direction of rotation		
		Output	Change of the state of 2 contacts: 1NO + 1NC	Opening of 2 NC contacts	Closing of 2 NO contacts
		Cial. reference	LUFN11	LUFN02	LUFN20
	Auxiliary signaling contacts block	Function	Indicates the open/ closed status of the protection: by NO/NC contact Protection standby/tripped: by SD contact To be inserted below the auxiliary module cavity (B)		
		Output	OF and SD contacts: NO type	OF contact: NC type	SD contact: NO type
		Cial. reference	LUA1C20	LUA1C11	
	Auxiliary signaling contacts block	Function	Indicates the open/closed status of the protection To be clamped on the left side of the power base.		
		Output	2 OF contacts: NO type		
		Cial. reference	LUA8E20		

The power bases are delivered with the following items

> **LUB12, LUB32**

12 or 32 A power base with imbedded control terminal block and 3 blanking shutters

> **LU2B12, LU2B32**

12 A (LUB120) or 32 A (LUB320 ⁽¹⁾) power base without imbedded control terminal block

+ 1 assembling connector **LU9MR1C**

+ 1 reverser block - vertical mounting **LU2MB0●●**

+ 1 control terminal block **LU9M1**

(1) see description next page.

Control terminal blocks - Characteristics

> **LU9BN1**

2 terminals → for coil

2 terminals → NO contact (24 ... 250 V DC/AC, 5 A max)

2 terminals → NC contact (24 ... 250 V DC/AC, 5 A max)

> **LU9M1**

1 terminal → common

1 terminal → S1 coil

1 terminal → S2 coil

2 terminals → contact NF (24 ... 250 V DC/AC, 5 A max)

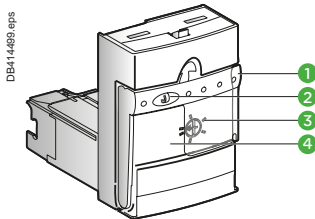

LUCA ●●●●

- 1 Extraction and locking handle.
- 2 Sealing of locking handle.
- 3 Ir adjustment dial.
- 4 Locking of settings by sealing the transparent cover.

They provide the electrical protection settings

LUCA - standard units

- Protection against overload: $14.2 \times I_r$ (setting current).
- Protection against short circuit: $13 \times I_r \text{ max}$ (max setting current).
- Protection against missing or unbalanced phases.
- Protection against insulation fault (protection of equipment only).
- Class 10 tripping.
- Frequency 50...60 Hz.

LUCL - magnetic units

- Protection against short circuits.
- To be used when a standard power base is connected to a motor drive or a soft starter, as they provide the overload protection.

Note: both LUCA and LUCL units can be used in the advanced power bases LUB120 and LUB320.

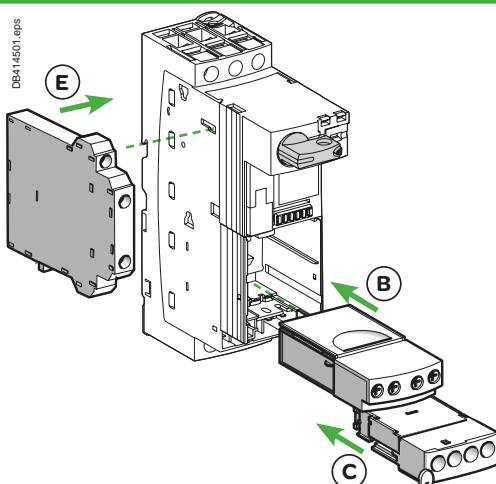

Modules and blocks are compatible with all standard and standard inverting power bases

Common electrical characteristics

- Standard operating voltage: 24...250 V AC/DC.
- Maximum current: 5 A.

- Rotation control: 1 direction - 2 directions.
- Protection: overload + short circuit + main power fault.
- Signaling: by dry contacts.
- Digital display of electrical values.
- Overload alarms.
- Network/bus communication.

1- Selection of the advanced power base and reverser block

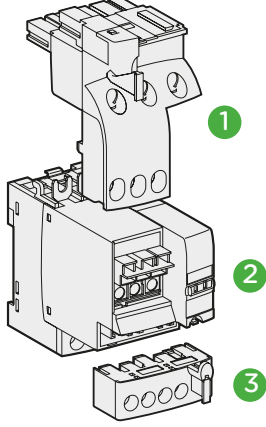
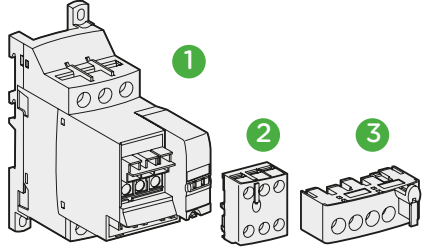
 <p>PE107367...eps</p>	 <p>DB416347 eps</p>	 <p>DB414503 eps</p>
Advanced power base	Reverser block - vertical mounting	Reverser block - side mounting
Rating / Ue AC 12 A / 400 et 500 V 9 A / 690 V 32 A / 400 V 23 A / 500 V 21 A / 690 V	LUB120 LUB320	1 LU9MR1C 2 LU2MB0●● (1) 3 LU9M1
		1 LU6MB0●● (1) 2 LU9MR1 3 LU9M1

(1) Terminal coil control A1-A2 and aux. NO + NC.

2- Selection of the control unit

Maximum standardized power ratings of 3 phases motors 50/60 Hz

				Setting range	Lip_in mounting on the power base - Rating	Protection type: - overload - short-circuit - Main power fault - alarm			Multifunctional
400/440 V	500 V		600 V			Class 10 3P	Class 10 1P	Class 20 3P	
kW	1P	3P	kW	A	A	LUCB6●●	LUCC6●●	LUCDX6●●	LUCM6BL
-	0.09	-	-	0.15...0,6	12 and 32	LUCB1X●●	LUCC1X●●	LUCD1X●●	LUCM1XBL
0.09	0.25	-	-	0.35...1,4	12 and 32	LUCB05●●	LUCC05●●	LUCD05●●	LUCM05BL
0.55	1.5	2.2	3	1.25...5	12 and 32	LUCB12●●	LUCC12●●	LUCD12●●	LUCM12BL
2.2	5.5	5.5	9	3...12	12 and 32	LUCB18●●	LUCC18●●	LUCD18●●	LUCM18BL
4	7.5	9	15	4.5...18	32	LUCB32●●	LUCC32●●	LUCD32●●	LUCM32BL
7.5	15	15	18.5	8...32	32				

Cial. ref. of the control unit: replace dots by the coil code.

Coil voltage (V)	24~	24~	48...72 ~ and 48~	110...220 ~ and 110...240~
Coil code	BL	B	ES	FU

> Selection of the modules and signaling blocks: see page A4/14

Magelis XBT NU HMI terminal (optional)



XBT NU400

Provides display and modification of the LUCM multifunctional controller settings. Ready to ensure dialogue with up to 8 TeSys U starter-controller (Modbus protocol - Pre-loaded application and alarm pages).

Main characteristics

- Multi-language: French, English, German, Spanish, Italian.
- Display: 4 lines of 20 characters.
- Width 132 mm, height 74mm, depth 43 mm.
- Supply voltage 24 V DC.

Designation	Reference
Magelis TeSys U terminal	XBTNU400
Connecting cable XBTNU400 to LUCM ●●BL, L = 2,50 m (1)	XBTZ938

(1) A Modbus hub or - junction must be used when connecting several TeSys U.

LUB120, LUB320 - 12 or 32 A advanced power base equipped with:

- One NO latching contact + one NC contact
- Operation voltage 24 ... 250V AC/DC - I max 5 A
- + 2 blanking shutters

The cavity C is empty, ready for insertion of a terminal block:

- > for local control **LU9BN11**
- > for centralized control **LU9BN11C, LU9BN11L**
- > or insertion of an assembling connector **LU9MR1C**, for reverser block - vertical mounting

Inverser block: its maximum controlled power might be limited by the power base capacity

Power base interlocking control:

- > vertical mounting: by the assembling connector **LU9MR1C**
- > side mounting: by a **LU9MR1** terminal block (to be linked to a **LU9B N11** terminal block in the advanced power base).

Reverse control:

- > Local control, to be wired on a **LU9M1** terminal block
- > centralized control, by a **LU9MRC** or **LU9MRL** terminal block; its connector must be plugged in a communication module, in the advanced power base.

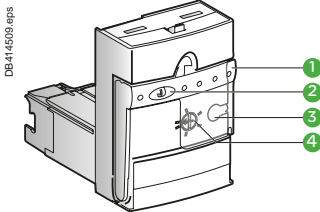

LUCB ●●●●, LUCC ●●●●, LUCD ●●●● control units

- 1 Extraction and locking handle.
- 2 Sealing of locking handle.
- 3 Ir adjustment dial.
- 4 Test push button.

LUCB, LUCC, LUCD control and diagnostic units

- Motor protection, fault diagnostic.
- Protection against
 - overload: $14.2 \times I_r$ (setting current).
 - Simulation of an overload by depressing the test push button.
 - short circuit: $13 \times I_r$ max (max setting current).
 - missing or unbalanced phases.
 - insulation fault (protection of equipment only).
- Overload alarm management:
 - locally: with one of the LUF family module
 - Remotely: with LULC031, LULC033, LULC07, LULC08, LULC09 or LULC15 (thermal alarm only) communication module.
- Reset:
 - manual
 - automatic, with a communication module.

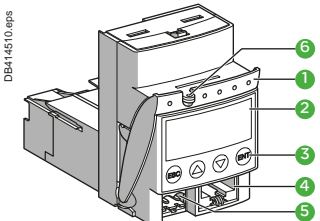

LUCM ●●BL control unit

- 1 Extraction and locking handle.
- 2 Built-in LCD display (2 lines, 12 characters).
- 3 4 button keyboard.
- 4 RS485 Modbus communication port, with RJ45 connector.
- 5 Connector for external 24 V DC power supply.
- 6 Sealing of locking handle.

LUCM multifunctional control unit

- Motor protection, operational values display and diagnostic.
- To be associated with 24 V DC coil only.
- LUCM ●●BL: tripping class 5 to 30, single phase, three phase
- Same functions as LUCB ●●●● with complementary functions:
 - in working mode: display of electrical values, setting parameters and events
 - in configuration mode: display of protection and alarm settings.
- These functions are available for local display on a display panel, and for remote display via a RJ45 Modbus connector.
- The Modbus - RS485 compatibility is ensured by the Magelis XBT display terminal or a PC with the PowerSuite software.

Note: a 24 V DC power supply is required during the configuration process.

Components for "advanced control" (continued)

- Rotation control: 1 direction - 2 directions.
- Protection: overload + short circuits + main power fault.
- Signaling: by dry contacts.
- Digital display of electrical values.
- Overload alarms.
- Network/bus communication.

3a- Selection of the modules and signaling blocks (optional)

DB124025.eps

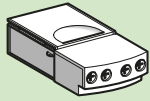

Function	Indicates the ON/OFF running status of the motor, whatever the direction of rotation		
Output	Change of the state of 2 contacts: 1NO + 1NC 5 A / 24 ... 250V AC/DC	Opening of 2 NC contacts 5 A / 24 ... 250V AC/DC	Closing of 2 NO contacts 5 A / 24 ... 250V AC/DC
Cial. reference	LUFN11	LUFN02	LUFN20

3b - Selection of additional function module (optional)



Function	Measure of average current in each phase	Alarm if average current in the phases = 105% of In	Indicates the overload tripping - manual reset	Indicates the overload tripping - reset with the power base control pad or remote reset	
Output	4-20 mA signal, image of the pourcentage of In	Closing of a NO contact	Change of state of 2 contacts: 1 NO + 1 NC	Opening of a NC contact	Closing of a NO contact
Référence	LUFV2	LUFW10	LUFDH11	LUFDA01	LUFDA10

4a- Selection of the auxiliary module and terminal block for Modicon Telefast system

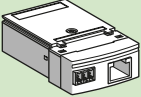
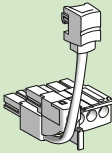
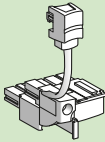
TeSys U

	Telefast system Module  DB414505.eps	Terminal block / control cable 1 direction of rotation  DB414506.eps	2 directions of rotation  DB414507.eps
Cial. reference	LUFC00	LU9BN11C use with LUB120 or LUB320	LU9MRC

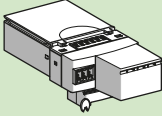
4b- Selection of the communication auxiliary module

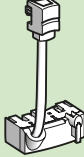
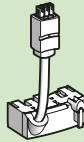
	Communication module  DB414508.eps	Terminal block / control cable for LUB... power base, 1 direction of rotation  DB414524.eps LU9BN11C	Terminal blocks / control cables for LU2B... ou LUB... + LU2MB0... power base, 2 directions of rotation  DB414526.eps LU9MRC  DB414527.eps LU9MRL
Modbus	LUL C033	LU9BN11C	LU9MRC
Ethernet	LUL C033 + TeSys port TCSEQM113M13M		
AS-Interface	ASILUF C51		
Profibus DP	LUL C07	LU9BN11L	LU9MRL
CANopen	LUL C08		
DeviceNet	LUL C09		
Advantys stb	LUL C15		
Beckhoff	LUL C14	contact us	

5- Selection of additional block signaling TeSys U status

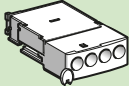
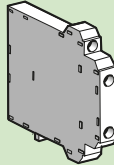
	Auxiliary signaling contacts block  DB124030.eps	Auxiliary signaling contacts block  DB414500.eps
Function	Indicates the off/ready status of TeSys U: by NO/NC contact Protection on/tripped: by SD contact To be inserted below the auxiliary module cavity (B)	Indicates the off/ready status of the protection
Output	OF and SD contacts: NO type	2 OF contacts: NO type
Cial. reference	LUA1C20	LUA1C11
		LUA8E20

- The signaling modules with dry contacts are directly wired on indicators and electrical warning devices.
- Contacts rating: 5 A / 24...250 V AC/DC.
- The **LUF V2** module is connected to a datalogger or any other indication device providing a 4-20 mA analog input.

- **Module LUF C00:**
 - indicates the position of the control pad and the state of the poles,
 - collects the FWD, REV commands from an automation process.
- **Inputs:** P24 V power base coil control, from a 24 V DC PLC output
- **Outputs:** OF / SD contacts from protection device, OF contact from the poles (to a 24 V PLC input)
- RJ45 connector for Telefast PLC pre-wiring system:
 - Modicon TM3 (map I/O controllers for RJ45 M221, M241, M25)
 - Modicon STB modules (I/O for automation island)
 - Modicon Telefast (interfaces RJ45/HE10).
- Must be connected to a **LU9 G02** or **LU9 G03** Telefast distribution box
- **Compatible exclusively with LUC●●● control unit with coil code B**
- The terminal blocks + control cables provide the connection to the coil of the power base and the signal contacts.

- **Communication modules:**
 - indicates the position of the control pad and the state of the poles,
 - collects the FWD, REV commands from an automation process.
- The states and the control orders are coded according to the selected communication protocol.
- Screw clamp terminals to the bus cable.
- The terminal blocks + control cables provide the connection to the coil of the power base and the signal contacts.

- **Additional blocks:**
 - used for wiring indicator lights or controllers.
- **Advantage:**
 - the locations for these blocks are always available, regardless of the configuration of the power base.
- **Contact rating:** 5 A / 24...250 V AC/DC.

Note: the indication the direction of rotation is available on the reverser block unit:
 - On a LU9M R1C assembling connector
 - On a LU9M R1 terminal block.

Standard or advanced power base

ON/OFF control (1 direction of rotation)

Push buttons wiring

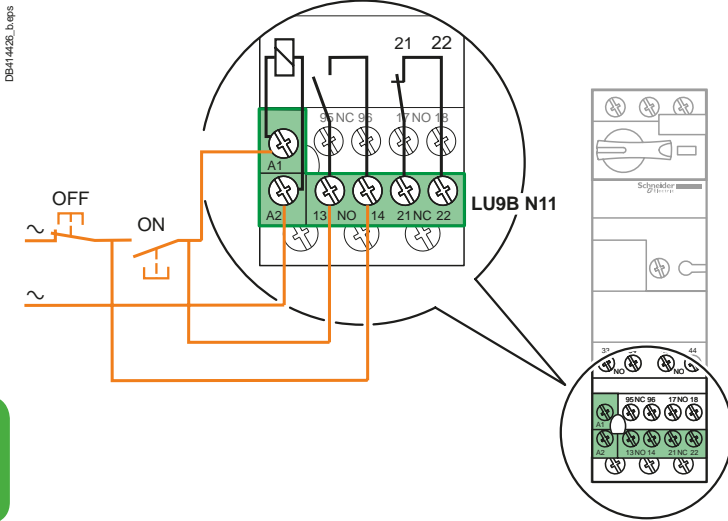

ON indication

"Motor RUN" indicator wiring

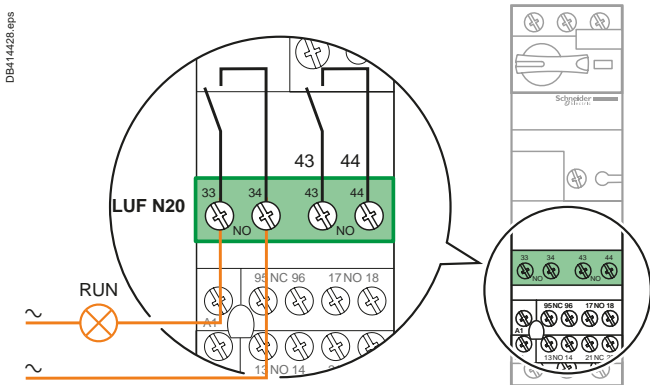

"Motor starter READY" indicator wiring

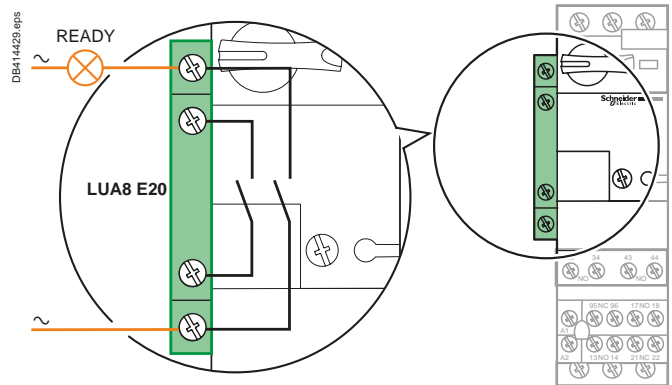

ALARM indication

Protection device status indicator wiring

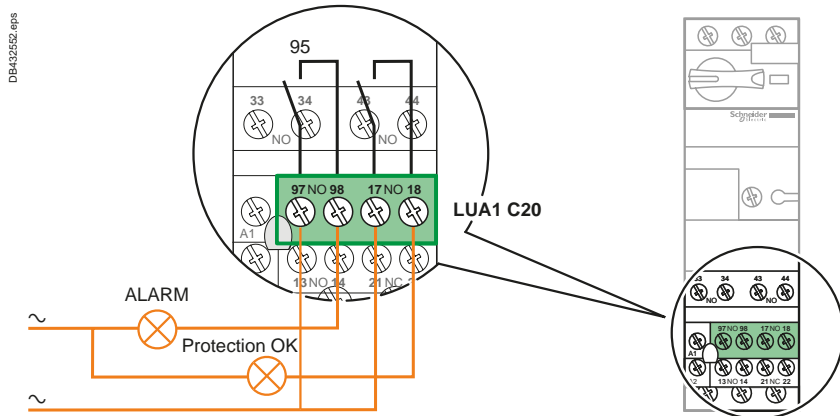

References

Typical wiring diagrams and contacts status

Power base with vertical mounting reverser block

FW/REV/OFF control (2 directions of rotation)

Push buttons wiring

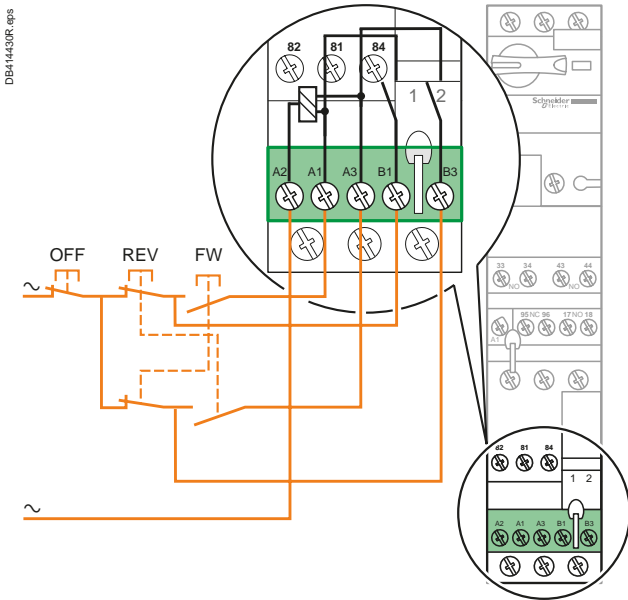

FW/REV control

FW, REV indicators wiring

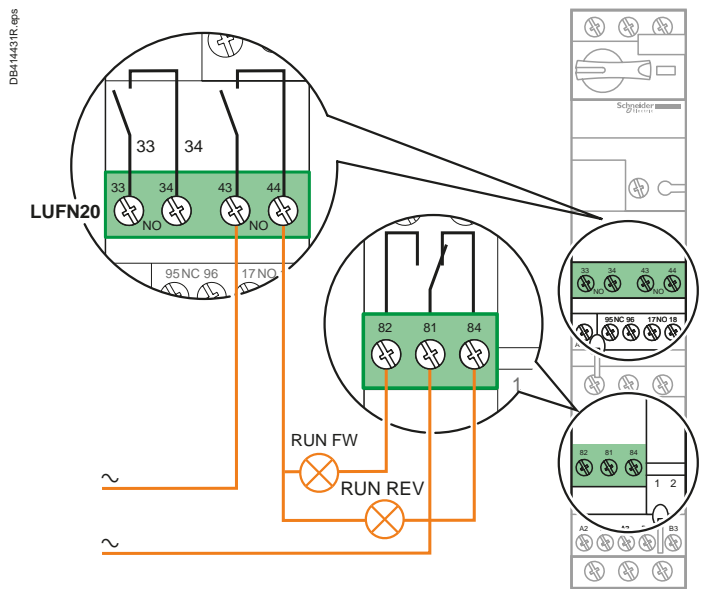

Contact states depending on the product status

	Position of rotary knob	Indication on front panel	N/O pole contact	N/C pole contact	N/O contact any fault	N/C contact any fault	N/O contact product ready	N/C contact Rotary knob on OFF position
References of add-on contact blocks and auxiliary contact modules Terminal referencing	–	–	–	LUF N11 31-32	LUA1 C20 97-98	LUA1 C11 95-96	LUA1 C20 17-18	–
	or	–	–	LUF N02 31-32 41-42	LUA1 C200 No terminal block	LUA1 C110 No terminal block	LUA1 C200 No terminal block	LUA8 E20 57/58 67/68
	or	–	–	LUF N20 33-34 43-44	LUB9 N11 21-22	–	LUA1 C11 17-18	–
	or	–	–	LUF N11 43-44	–	–	LUA1 C110 No terminal block	–
	or	–	–	LUB9 N11 13-14	–	–	–	–
Off	OFF	0						
Ready to operate		0						
Start		1						
Tripped on short-circuit	TRIP	l>>						
Tripped on thermal overload	Manual reset mode	TRIP						
	Automatic reset on thermal overload fault mode							
	Remote reset mode		0					

N/O contact in closed position.

N/C contact in open position.

PB 106/09/09 eps

TeSys U



Point-to-point wiring

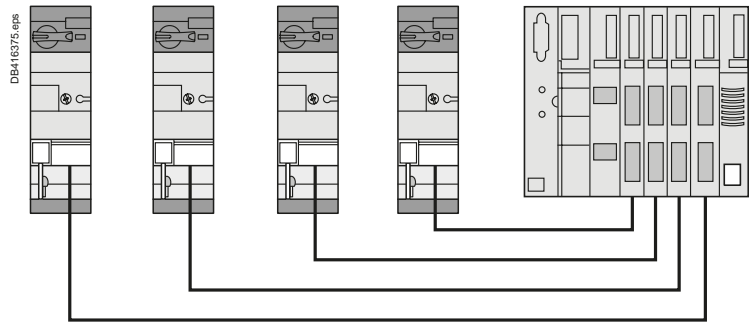

- The control inputs and signaling outputs of the starter are grouped in a single socket, usually RJ45. They are individually connected to PLC outputs and inputs.
- The wires run in parallel in a multicore cable equipped with a multipin connectors, RJ45 in the case of Telefast type system.
- 3 parallel wiring systems are available:
 - Modicon TM3, based on a RJ45 I/O module for M221, M241, M25 PLC
 - Modicon STB, based on I/O modules for automation island
 - Modicon Telefast: RJ45 / HE10 interfaces.
- Simple way of proximity wiring. Quick cabling. It is suitable for machine control panels when a large number of TeSys U starter-controller are installed.

Informations

- The control and signaling terminals of the starters are connected to the output and input terminals of a PLC. No specific connectors or cables are required.
- Conventional wiring mode, without optimization of the cabling time. May be suitable when a very small number of starters is used, with a very small number of links.

Parallel cabling systems

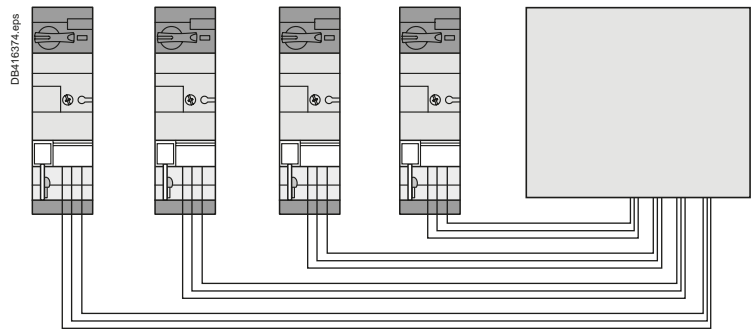

Integration in the Modicon TM3 wiring system

The TeSys U starter-controller are directly connected to a I/O module equipped with RJ45 connectors.

- 1 Modicon M221, M241, M251 PLC's
- 2 TM3XTY I/O module for 4 starters
- 3 LU9R●● cables with RJ45 connectors,
- 4 LUFC00 module for TeSys parallel connection (1 or 2 direction of rotation).

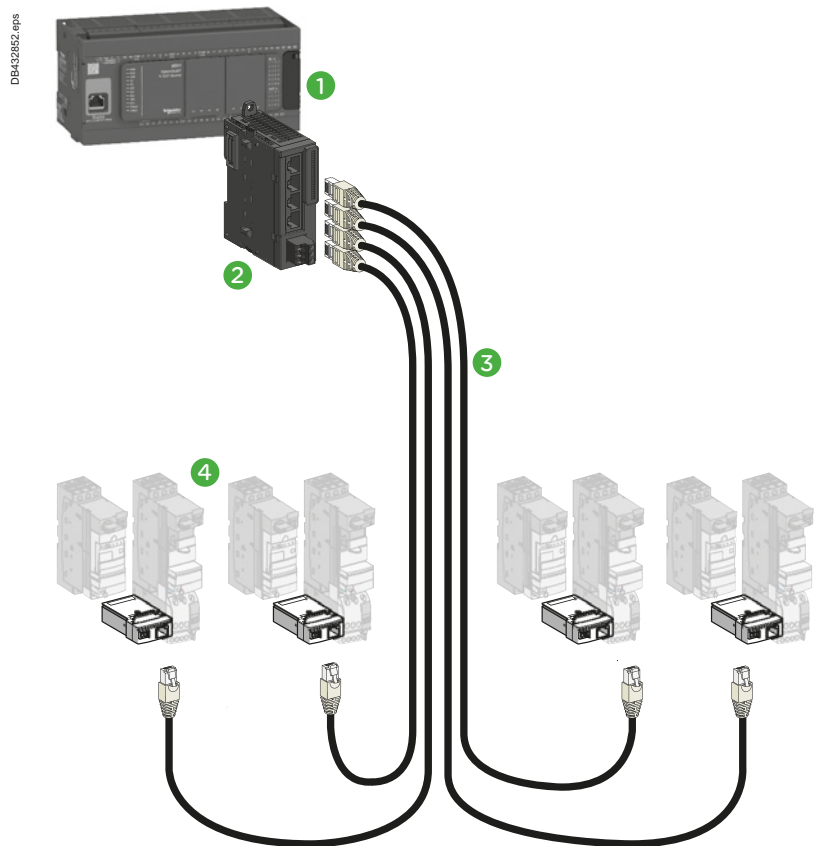

Integration in the Modicon Advantys STB system

Advantys STB is a solution for remote I/O modules.

These communicate with the Modicon PLCs range thanks to a serial liaison, using the Advantys STB protocol.

In this example an Advantys I/O module is used to facilitate wiring.

Each of its four terminals receives a preassembled RJ45 cable connected to a TeSys U starter-controller.

- 1 TeSys U starter-controller (equipped with 24 V DC LUC ●●●● BL control modules)
- 2 TeSys module for parallel RJ45 wiring: LUFC00 + LU9B N11C (one direction) or LU9MRC (2 directions)
- 3 RJ45 cables (2 connectors):
 - ≤ 3 m: LU9 R●●
 - > 3 m: 490 NTW 000●● (5, 12, 40 or 80 m)
- 4 PLC: Modicon range
- 5 I/O Modicon Advantys module: STB EPI 2145K

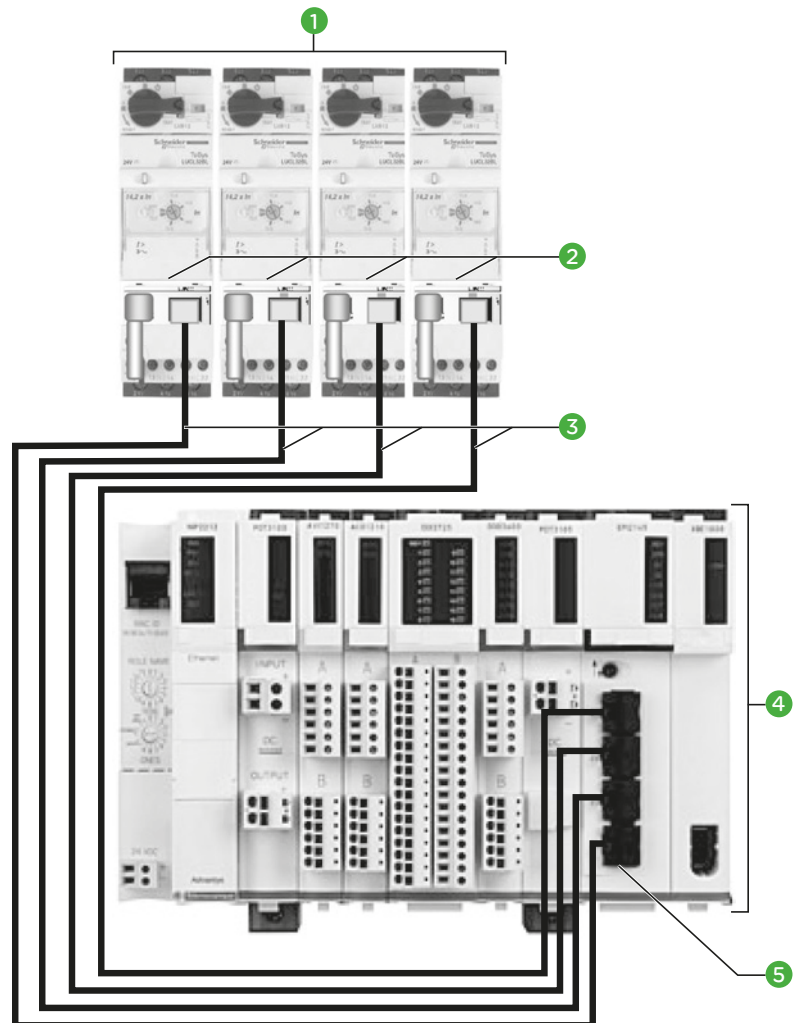

Integration in the Modicon Telefast system

The wiring hubb **LU9G0●** facilitates the connection to Modicon Premium PLCs.

It adapts RJ45 connectors to HE10 available on the Telefast I/O modules.

Connection: up to 8 TeSys U per hubb.

- 1 TeSys U starter-controllers (equipped with 24 V DC LUC ●●●●BL control units)
- 2 TeSys Module for parallel wiring RJ45: LUF C00 + LU9B N11C (one direction) or LU9MRC (2 directions)
- 3 RJ45 cables (2 connectors):
 ≤ 3 m: LU9R●●
 > 3 m: 490 NTW 000●● (5, 12, 40 or 80 m)
- 4 Telefast RJ45 / HE10 splitter box: LU9G02 or LU9G03 (different TeSys U connection capacities)
- 5 HE10 cables (2 connectors): TSX CDP ●●●
- 6 PLC: Modicon Premium range
- 7 I/O module: TSX DMY 28FK

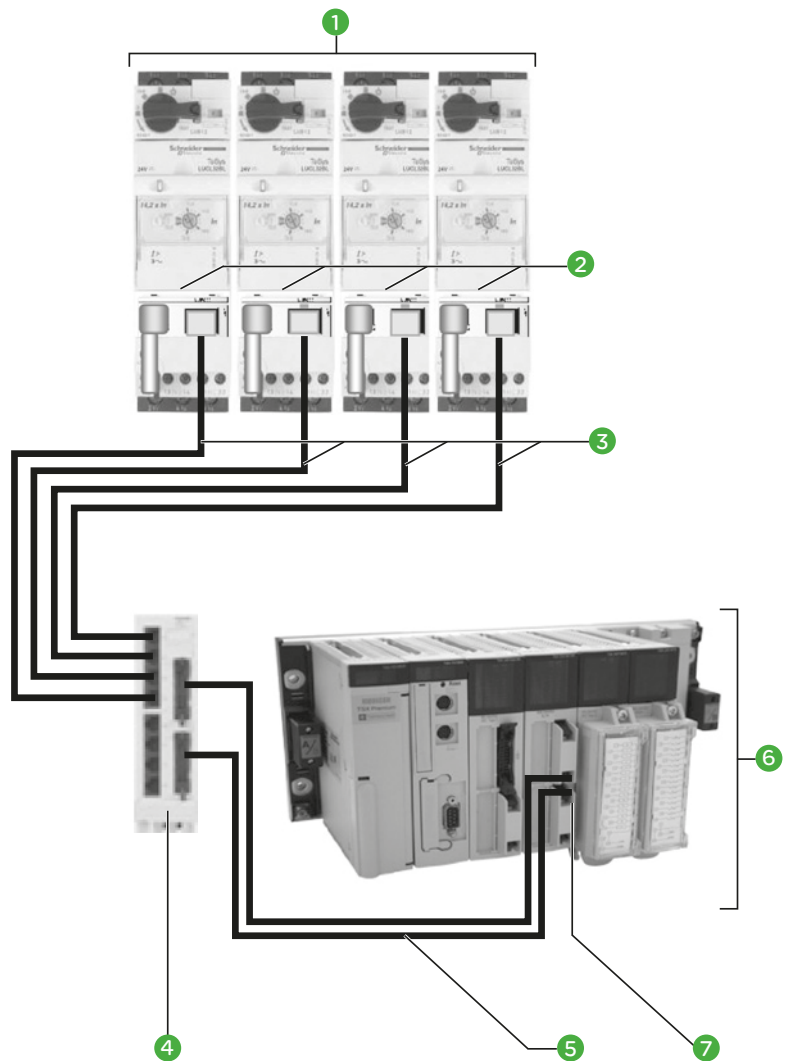

TeSys U

References

Parallel-type cabling systems

Components TeSys U

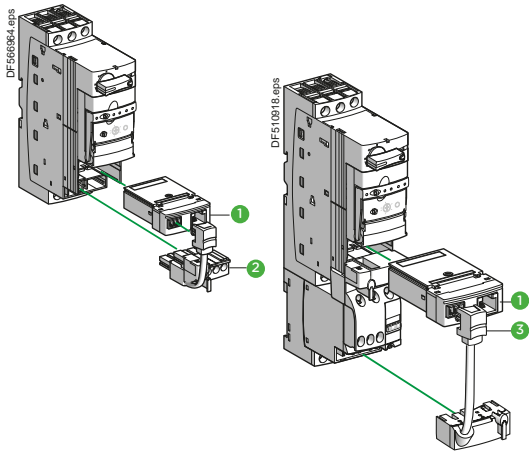

Components for connection of a starter - 1 direction of rotation

Designation	Reference
1 Parallel connection module, RJ45 output 2 coil control inputs, 3 signal outputs	LUFC00
2 Pre wired connector, one direction of rotation, for coil connection and one contact for emergency stop	LU9BN11C

Components for connection of a starter - 2 directions of rotation

Designation	Reference
1 Parallel connection module, RJ45 output	LUFC00
3 Pre wired connector, 2 directions of rotation, for coil connection and one contact for emergency stop	LU9MRC

TeSys U



LU9 G02



LU9 G03

Telefast RJ45/ HE10 splitter box

Designation	Reference
Splitter box Connection to TeSys U: 4 RJ45 connectors: for 1 to 4 TeSys U, 1 or 2 directions 4 RJ45 connectors: for 1 to 4 TeSys U, 1 direction Connection to PLC: 1 x HE10 connector - 20 channels, for pole status, alarms 1 x HE10 connector - 20 channels, for control. 24 V DC auxiliary power supply required	LU9G02
Splitter box Connection to TeSys U: 8 RJ45 connectors: for 1 to 8 TeSys U, 1 or 2 directions Connection to PLC: 1 x HE10 connector - 20 channels, for pole status, alarms 1 x HE10 connector - 20 channels, for control. 24 V DC auxiliary power supply required.	LU9G03

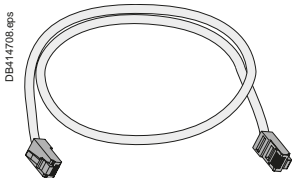

RJ45 cables.

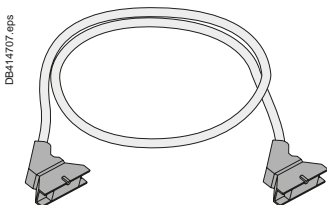

HE10 cables.

RJ45 connection cables, with 2 RJ45 connectors

0,3 m	LU9R03
1 m	LU9R10
3 m	LU9R30

HE10 connection cables, with 2 HE10/20 way connectors

Section: AWG 22 / 0.324 mm ²	
0,5 m	TSXCDP053
1 m	TSXCDP103
2 m	TSXCDP203
3 m	TSXCDP303
5 m	TSXCDP503
Section: AWG 28 / 0.080 mm ² (flat cable)	
1 m	ABFH20H100
2 m	ABFH20H200
3 m	ABFH20H300

HE10 connection cables, with 1 x HE10/40 way connector (PLC side) and 1 x HE10/20 way connector (Splitter box side)

Section: 0.324 mm ²	
0,5 m	BMXFCC053
1 m	BMXFCC103
2 m	BMXFCC203
3 m	BMXFCC303
5 m	BMXFCC503
10 m	BMXFCC1003

Cable with stripped wires (PLC side) 1 x HE10/20 ways connector (Splitter box side)

Section: AWG 22 / 0.324 mm ²	
3 m	TSXCDP301
5 m	TSXCDP501

PB105092.eps



> Application functionality, topology

1 Geographically expanded process

Many motors are scattered on the site, the process control requires individual control to ensure safety and proper operation.

TeSys U is a suitable communicating actuator. The integration of a bus communication module in the starter-controller saves space in the control board and simplifies wiring, compared to solutions based on conventional components (circuit breaker + contactor).

2 Application: automatic motor control / monitoring

Thanks to a communication bus, starter-controllers are part of an automation system controlled by a PLC and (or) various communicating controllers.

These equipment can then share the status and alarm information related to each motor control and perform specific treatments.

3 Bus-type connection

This type of connection allows different topologies (star, ring ...) and supports various protocols dialogue. It is therefore recommended for geographically expanded process, in order to to simplify wiring and ensure multiple-controller management.

- The bus wiring interconnects TeSys U starters controllers and components of the installation via a single the cable.
- Commands and status are coded according to the selected protocol and transmitted on the communication bus.
- This wiring is simple, usually a shielded (or not) pair of wires, suitable for monitored automation, regardless of the number of TeSys U and their locations.

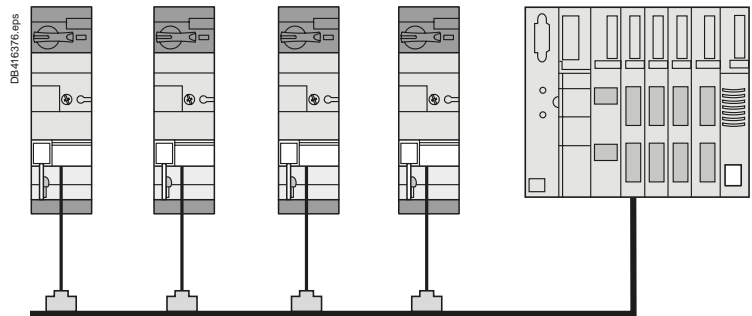

Available TeSys U status and controls via a communication module

Control unit	LUCA	LUCB LUCC LUCD	LUCM
Starter status (ready, running, fault)	■	■	■
Start and Stop commands	■	■	■
Thermal overload alarm		■	■
Remote reset via the bus		■	■
Indication of motor load		■	■
Fault signalling and differentiation		■	■
Remote programming and monitoring of all functions			■
"Log" function			■
"Monitoring" function			■
Alarms (overcurrent, ...)			■

TeSys U

Network

Architecture

Component references

AS Interface

Cabling system for rapidly connecting sensors and actuators to the controller. A single cable provides both data transmission and power to sensors.

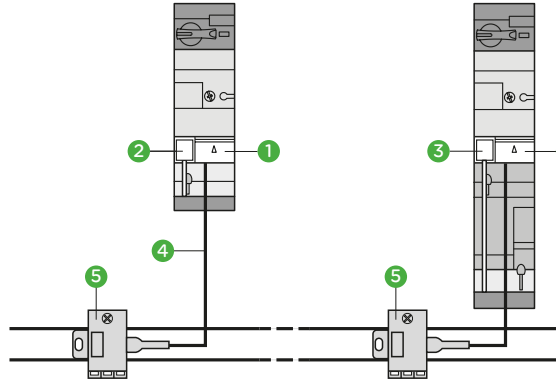

- 1 ASI LUF C5 or ASI LUF C51
- 2 LU9B N11C
- 3 LU9M RC
- 4 XZ CG0142
- 5 TC SAT V01 N2

Details page

A4/26

CANopen

Etoile

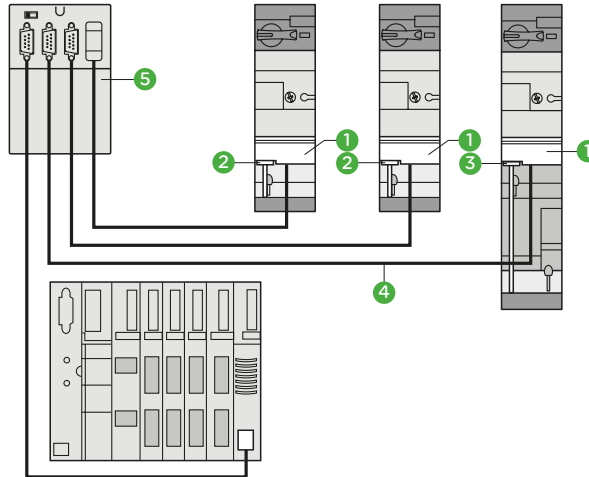

- 1 LUL C08
- 2 LU9B N11L
- 3 LU9M RL
- 4 TSX CAN C●●●
- 5 TSX CAN TDM4
- 6 TSX CPP 110

Bus

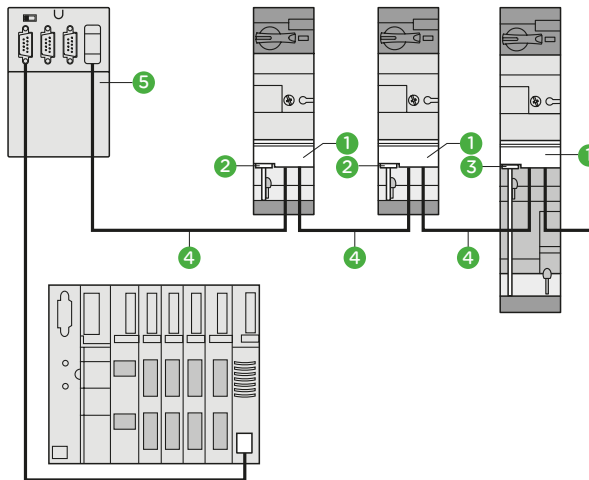

Details page

A4/27

Network

Architecture

Component references

Modbus

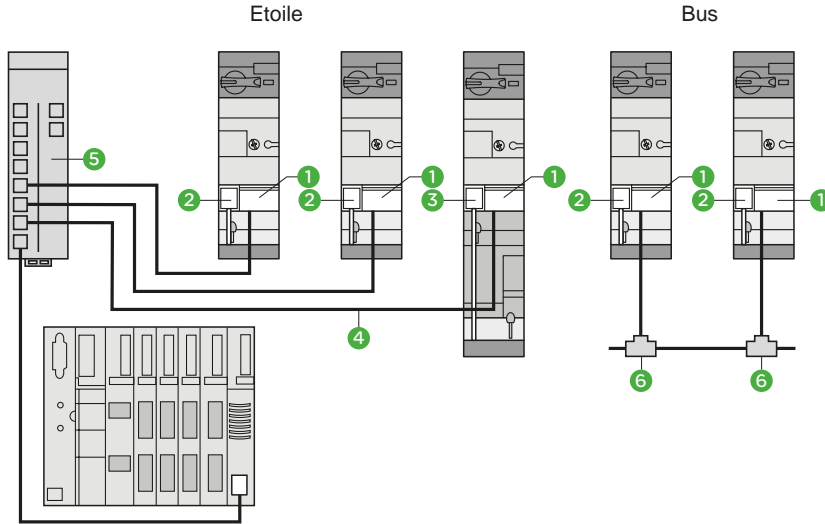

- 1 LUL C031 or LUL C033
- 2 LU9B N11C
- 3 LU9M RC
- 4 VW3 A8 306R...
- 5 LU9 GC3
- 6 VW3 A8 306TF

Details page
A4/28

Advantys STB

Starter-controllers communicate using ADVANTYS STB protocol to fit into a remote I/O architecture.

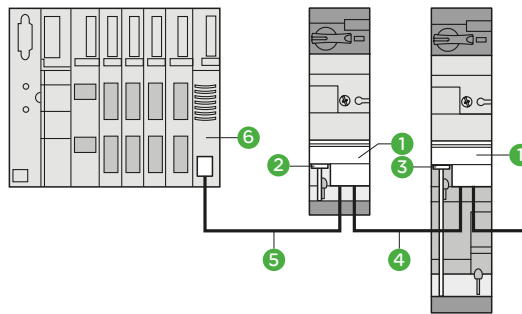

- 1 LUL C15
- 2 LU9B N11L
- 3 LU9M RL
- 4 LU9 RDD...
- 5 LU9 RCD
- 6 STB XBE1100

Details page
A4/29

Profibus-DP (Decentralized Peripherals)

is used for connecting actuators and sensors to a central controller for applications in industrial production. The standard bus provides a number of diagnostic means

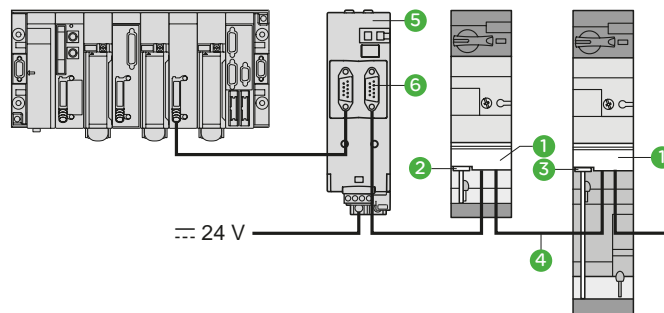

- 1 LUL C07
- 2 LU9B N11L
- 3 LU9M RL
- 4 LU9 RPB010
LU9 RPB100
LU9 RPB400
- 5 LU9 AD7
- 6 LU9 GC7

Details page
A4/30

DeviceNet

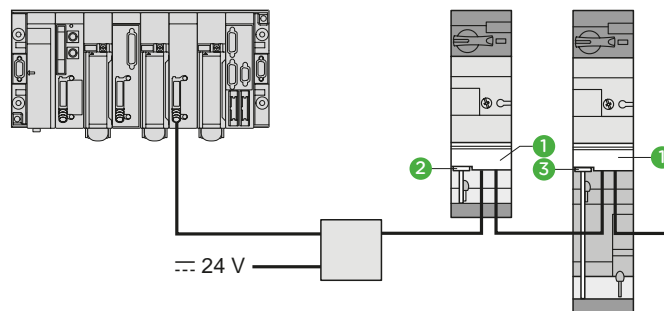

- 1 LUL C09
- 2 LU9B N11L
- 3 LU9M RL

Details page
A4/31

TeSys U

References

Bus-type cabling systems

TeSys U components for AS-Interface bus

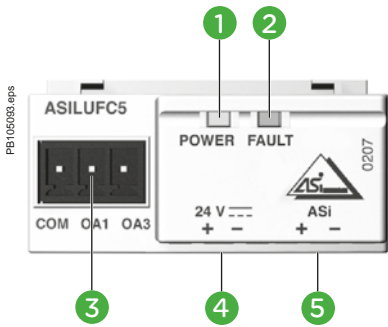

- 1 Green LED: AS-Interface voltage present
- 2 Red LED: AS-Interface or module fault
- 3 Outputs for starter commands
- 4 Black connector for connection to 24 V auxiliary power supply
- 5 Yellow connector for connection to the AS-Interface system

The LULC09 communication module, combined with the power base and control unit is used to control TeSys U starters-controllers via DeviceNet bus. The LULC09 communication module is slave type.

Module Specifications

I/O terminal block

- Powered by external 24 V DC (power supply not included):
 - 2 x configurable inputs for binary sensors
 - 1 x 24 V DC output - 0.5 A local auxiliary command.

Connectors

- For TeSys U 24 V DC coil (common, direction 1, direction 2).
- For AS-Interface bus.

Signaling

- Module Status - Error - 24 V, by LED.

TeSys components

Description	Mark	Max number of slaves	References
AS-Interface communication module	1	31	ASILUFC5
		62	ASILUFC51
Pre-wired connector: coil - LUB powerbase	2	-	LU9BN11C
Pre-wired connector: coil - LUB2B powerbase	3	-	LU9MRC

Connection of the communication module

By a "Y" cable with:

- TeSys U side, 2 connectors (bus + power),
- Bus side, one connector to be connected to the AS-Interface TCSATV01N2 tap-off.

Description	References
AS-Interface / TeSys U branch cable, L = 2 m	XZCG0142
AS-Interface Tap-off	TCSATV01N2

TeSys U

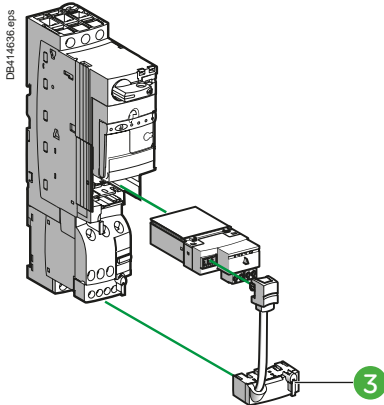
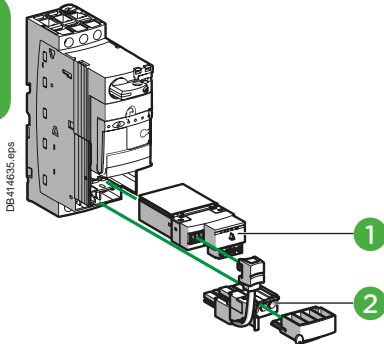

References

Bus-type cabling systems

TeSys U components for CANopen bus

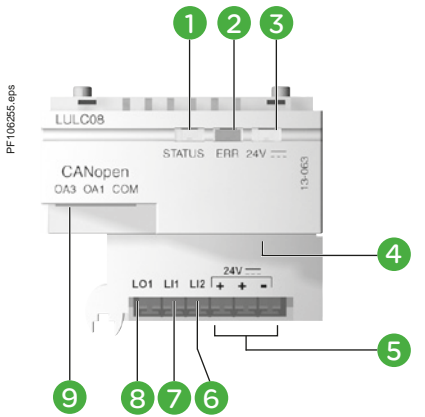

- 1 LED indicating module status
- 2 Fault signalling LED
- 3 LED indicating 24 V supply ON for outputs OA1, OA3 and LO1
- 4 SUB-D connector for bus link
- 5 24 V supply connection
- 6 Discrete input
- 7 Discrete input
- 8 Discrete output
- 9 Outputs for starter commands

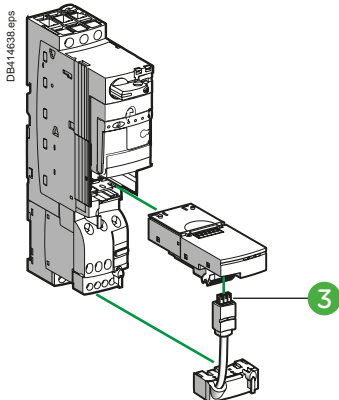
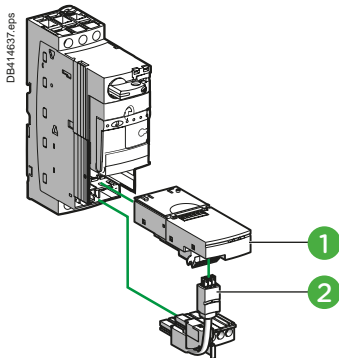

The LUL C08 communication module, combined with the power base and control unit is used to control TeSys U starters-controllers via CANopen bus. The LULC08 communication module is slave type.

Module Specifications

I/O terminal block

- Powered by external 24 V DC (power supply not included):
 - 2 x configurable inputs for binary sensors
 - 1 x 24 V DC output - 0.5 A local auxiliary command.

Connectors

- For TeSys U 24 V DC coil (common, direction 1, direction 2).
- For CANopen bus.

Signaling

- Module Status - Error - 24 V, by LED.

Tesys components

Description	Item	References
CANopen communication module	1	LULC08
Pre-wired connector: coil - LUB powerbase	2	LU9BN11L
Pre-wired connector: coil - LUB2B powerbase	3	LU9MRL

Compatibility of CANopen communication module with control units

LUCA ●●BL / B ●●BL / C ●●BL / D ●●BL	All versions marketed after 2T0481 ⁽¹⁾
LUC M●●BL	All versions ≥ V3.2
LUC MT1BL	All versions ≥ V3.2

(1) This "date code" is made up as follows:
2T or **2C**: factory code.
04, 05, 06 and so on: year of manufacture.
08: week.
1: 1st day of the week.

How to get information on the design of a CANopen architecture and the choice of network accessories

Consult the library of downloadable documents on schneider-electric.com by searching on the name of the communication protocol.

References

Bus-type cabling systems

TeSys U components for Modbus bus

LUL C031

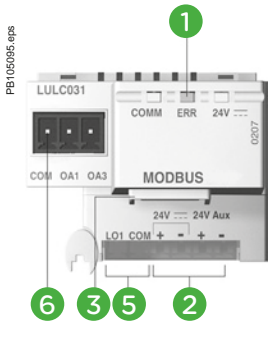

LUL C033

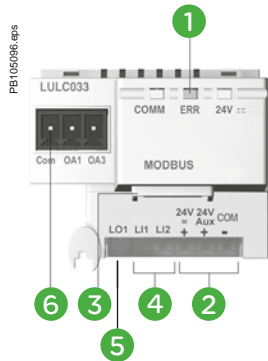

- 1 Module status signalling LED
- 2 24 V supply connection
- 3 RJ45 connector for RS485 Modbus link
- 4 2 discrete inputs
- 5 1 discrete output
- 6 Outputs for starter commands

The LULC031 and LULC032 communication modules, combined with the power base and control unit is used to control TeSys U starters-controllers via Modbus.

Module Specifications

I/O terminal block

- Powered by external 24 V DC (power supply not included):
- 2 x configurable inputs for binary sensors (on LULC033 only)
- 1 x 24 V DC output - 0.5 A local auxiliary command.

Connectors

- For TeSys U 24 V DC coil (common, direction 1, direction 2).
- RJ45, For Modbus line.

Signaling

- Module Status - Error - 24 V, by LED.

TeSys U

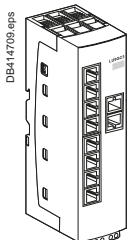
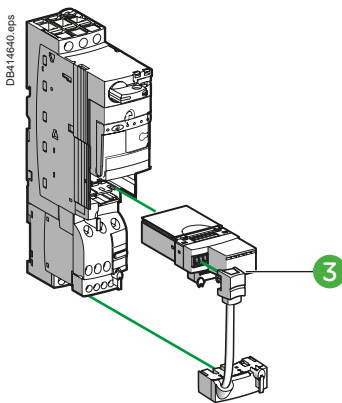
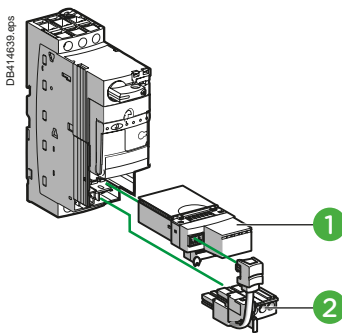

Tesys components

Description	Item	Bin. input	References
Modbus communication module	1	0	LULC031
		2	LULC033
Pre-wired connector: coil - LUB powerbase	2	-	LU9BN11C
Pre-wired connector: coil - LUB2B powerbase	3	-	LU9MRC

Modbus hub

Description	Length (m)	References
Modbus communication distributor	-	LU9GC3
Cables fitted with 2 x RJ45 connectors	0.3	VW3A8306R03
	1	VW3A8306R10
	3	VW3A8306R30
Tees derivations	0.3	VW3A8306TF03
	1	VW3A8306TF10

Description	References
RS 485 line terminator	VW3A8306R

Compatibility of Modbus communication modules

Communication modules (software version)		LUCL C031 from V2.3	LUCL C033 from V2.1	LUCL C033 from V2.2
Power base	LUB ●● / LU2B ●2	■	■	■
	LUTM ●●BL		■	■
Control unit	LUCA ●●BL	■		■
	LUCB ●●BL	■		■
	LUCU ●●BL			■
	LUCD ●●BL			■
	LUCM ●●BL	■		■ ⁽¹⁾
	LUCBT ●●BL		■	
	LUCDT ●●BL			■
LUCMT ●●BL		■		

(1) Except LUCM ●●BL V1.04 and V1.06.

How to get information on the design of a Modbus architecture and the choice of network accessories

Consult the library of downloadable documents on schneider-electric.com by searching on the name of the communication protocol.

References

Bus-type cabling systems

TeSys U components for Advantys STB bus

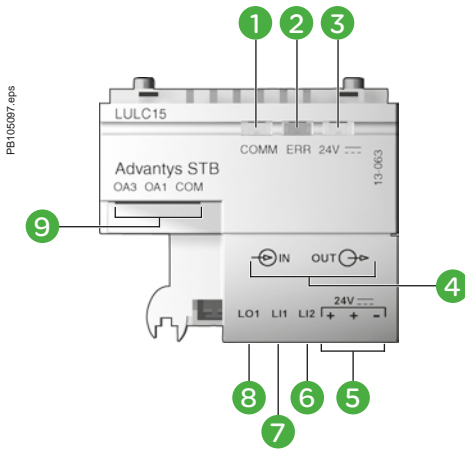

- 1 Two-colour LED indicating module status
- 2 Fault signalling LED
- 3 LED indicating that 24 V supply is ON
- 4 Bus connectors
- 5 24 V supply connection
- 6 Discrete input
- 7 Discrete input
- 8 Discrete output
- 9 Outputs for starter commands

Communication module LUL C15 allows direct connection of TeSys U starter-controllers and controllers on an Advantys STB island, between two segments or at the end of a segment. The starter-controller will then be able to make use of the services provided by Advantys STB: self-addressing, autobaud, fallback positions.

Module Specifications

I/O terminal block

- Powered by external 24 V DC (power supply not included):
- 2 x configurable inputs for binary sensors (on LULC033 only)
- 1 x 24 V DC output - 0.5 A local auxiliary command.

Connectors

- For TeSys U 24 V DC coil (common, direction 1, direction 2).
- For Advantys STB bus.

Signaling

- Com - Error - 24 V, by LED.

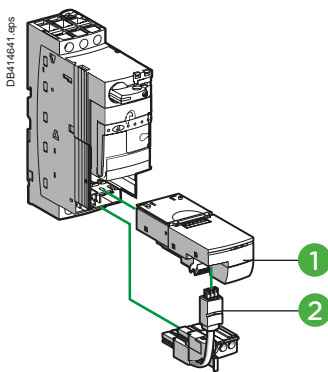

LUB + LUL C15 + LU9BN11L

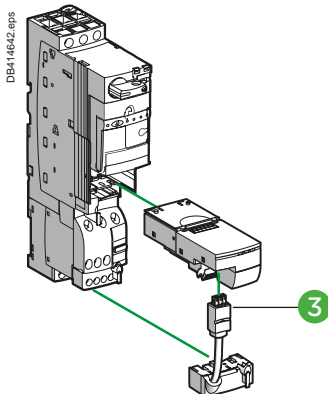

LU2B + LUL C15 + LU9M RL

Tesys components

Description	Item	References
Advantys STB communication module	1	LULC15
Pre-wired connector: coil - LUB powerbase	2	LU9BN11L
Pre-wired connector: coil - LUB2B powerbase	3	LU9MRL

Cables

Description	Length (m)	References
Cables fitted with connectors, one straight and one elbowed	0.3	LU9RCD03
	1	LU9RCD10
	3	LU9RCD30
	5	LU9RCD50
Cables fitted with two straight connectors	0.3	LU9RDD03
	1	LU9RDD10
	3	LU9RDD30

Compatibility of Advantys STB communication module with control units

LUCA ●●BL / B ●●BL / C ●●BL / D ●●BL	All versions marketed after 2T0481 ⁽¹⁾
LUCM ●●BL	All versions ≥ V3.2
LUCM T1BL	All versions ≥ V3.2

- (1) This "date code" is made up as follows:
2T or **2C**: factory code.
04, 05, 06 and so on: year of manufacture.
08: week.
1: 1st day of the week.

How to get information on the design of a Advantys STB architecture and the choice of network accessories

Consulter la librairie des documents téléchargeables sur le site schneider-electric.com en faisant une recherche sur le nom du protocole de transmission.

References

Bus-type cabling systems

TeSys U components for Profibus DP bus

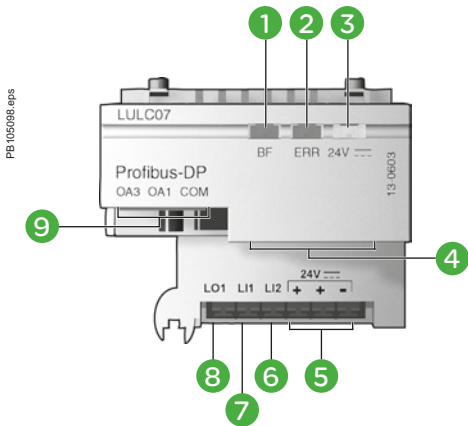

- 1 Two-colour LED indicating module status
- 2 Fault signalling LED
- 3 LED indicating 24 V supply ON for outputs OA1, OA3 and LO1
- 4 SUB-D connector for bus link
- 5 24 V supply connection
- 6 Discrete input
- 7 Discrete input
- 8 Discrete output
- 9 Outputs for starter-controller commands (non-reversing and reversing)

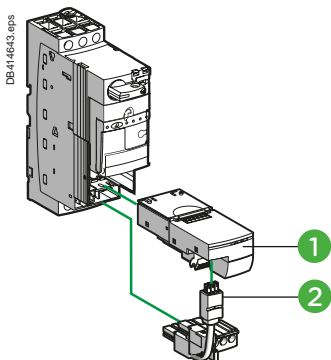

LUB + LUC ●●●BL + LUL C07 + LU9B N11L

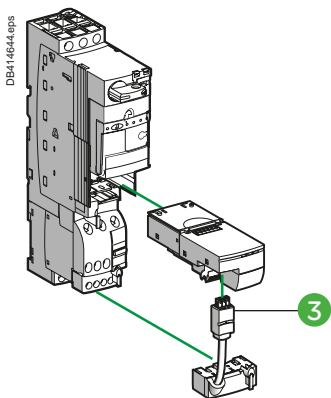

LU2B + LUC ●●●BL + LUL C07 + LU9 MRL

When used in conjunction with the power base and control unit, communication module LULC07 allows TeSys U starter-controllers to be controlled via Profibus DP (Deported Periphery) bus. Communication module LULC07 is of the slave type.

Module Specifications

I/O terminal block

- Powered by external 24 V DC (power supply not included):
- 2 x configurable inputs for binary sensors
- 1 x 24 V DC output - 0.5 A local auxiliary command.

Connectors

- For TeSys U 24 V DC coil (common, direction 1, direction 2).
- For Profibus DP bus.

Signaling

- Com - Error - 24 V, by LED.

Tesys components

Description	Item	References
Profibus DP communication module	1	LULC07
Pre-wired connector: coil - LUB powerbase	2	LU9BN11L
Pre-wired connector: coil - LUB2B powerbase	3	LU9MRL

Components for connection to the bus and to the installation

The 24 V DC -Aux supply to Profibus DP modules LUL C07 must pass through power supply module LU9 GC7. LUL C07 modules must be connected to the LU9 GC7 splitter box in order to be powered. The number of TeSys U starter-controllers that can be powered by an LU9 GC7 module is limited by the maximum current (1.5 A) which it can deliver. The 24 V supply for the inputs/outputs must be provided separately..

Description	Length (m)	References
Profibus DP power supply module	-	LU9GC7
Profibus DP connector	-	LU9AD7
Profibus DP cables 2-wire	100	TSXPBSCA100
	400	TSXPBSCA400
Profibus DP cables 4-wire	10	LU9RPB010
	100	LU9RPB100
	400	LU9RPB400

How to get information on the design of a Profibus DP architecture and the choice of network accessories

Consult the library of downloadable documents on schneider-electric.com by searching on the name of the communication protocol.

References

Bus-type cabling systems

TeSys U components for DeviceNet bus

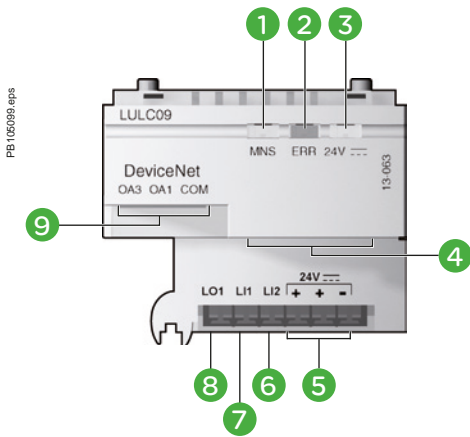

- 1 LED indicating module status
- 2 Fault signalling LED
- 3 LED indicating 24 V supply ON for outputs OA1, OA3 and LO1 and 24 V bus
- 4 DeviceNet connector for bus link
- 5 24 V supply connection
- 6 Discrete input
- 7 Discrete input
- 8 Discrete output
- 9 Outputs for starter-controller commands (non-reversing and reversing)

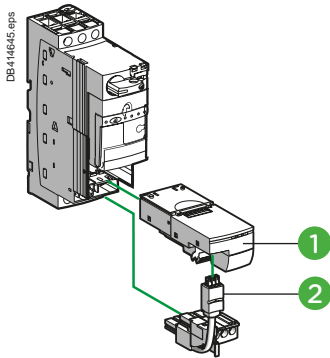

LUB + LUC ●●●BL + LUL C07 + LU9B N11L

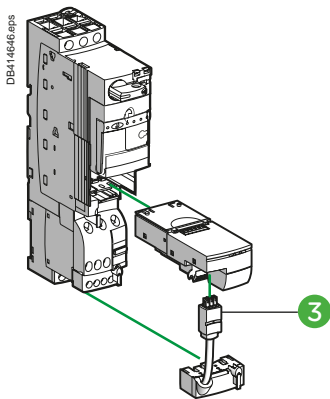

LU2B + LUC ●●●BL + LUL C07 + LU9 MRL

When used in conjunction with the power base and control unit, communication module LULC09 allows TeSys U starter-controllers to be controlled via DeviceNet bus. Communication module LUL C09 is of the slave type.

Module Specifications

I/O terminal block

- Powered by external 24 V DC (power supply not included):
- 2 x configurable inputs for binary sensors
- 1 x 24 V DC output - 0.5 A local auxiliary command.

Connectors

- For TeSys U 24 V DC coil (common, direction 1, direction 2).
- For DeviceNet bus.

Signaling

- Com - Error - 24 V , by LED.

Tesys components

Description	Item	References
DeviceNet communication module	1	LULC09
Pre-wired connector: coil - LUB powerbase	2	LU9BN11L
Pre-wired connector: coil - LUB2B powerbase	3	LU9MRL

How to get information on the design of a DeviceNet architecture and the choice of network accessories

Consult the library of downloadable documents on schneider-electric.com by searching on the name of the communication protocol.

Communication gateways LUFFP



108116_SE_Fraps

TeSys U

Presentation

Communication gateways LUFFP allow connection between the Modbus serial link and Fipio, Profibus DP or DeviceNet field buses.

After configuration, these gateways manage information which can be accessed by the Modbus serial link and make this information available for read/write functions (command, monitoring, configuration and adjustment) on the field buses.

An LUFFP communication gateway consists of a box which can be clipped onto a 35 mm omega rail, allowing connection of up to 8 Slaves connected on the Modbus serial link.

Example of architecture

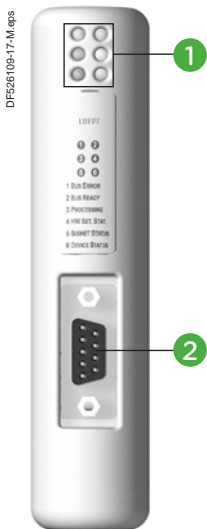
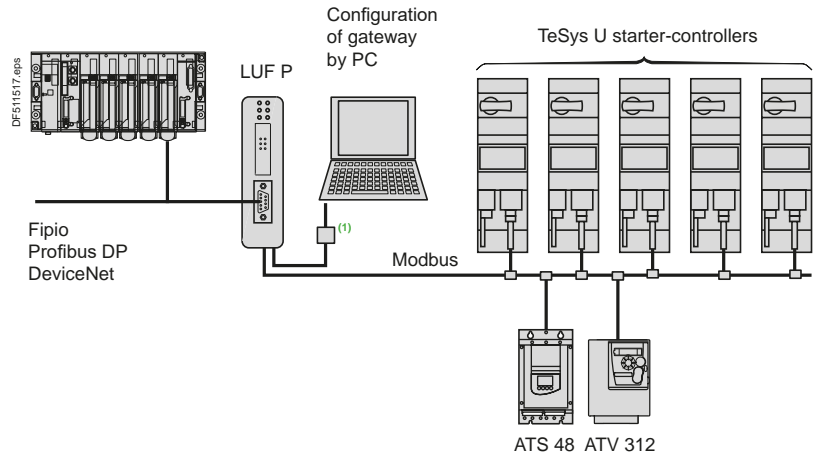

DF526109-17-M.eps

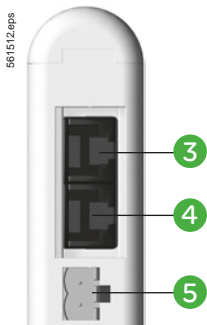

561512.eps

Communication gateway LUFFP

Description	Reference
Fipio / Modbus gateway	LUFFP1
Profibus DP / Modbus gateway	LUFFP7
DeviceNet / Modbus gateway	LUFFP9

Description

Front panel of the product

- ① LED indicating :
 - communication status of the Modbus serial links,
 - gateway status,
 - communication status of the Fipio, Profibus DP or DeviceNet bus.
- ② Connectors for connection to Fipio, Profibus DP or DeviceNet buses.

Underside of product

- ③ RJ45 connector for connection of the Modbus serial link
- ④ RJ45 connector for link to a PC
- ⑤ 24 V power supply

Software set-up

For the Fipio bus, software set-up of the gateway is performed using either PL7 Micro/Junior/Pro software or ABC Configurator software.

For the Profibus DP and DeviceNet buses, software set-up is performed using ABC Configurator.

This software is included in the TeSys U user's manual.

(1) Connection kit for PowerSuite software workshop.

References

Current limiter blocks and accessories

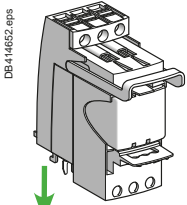

DB414652.eps



PB113546.eps

LUA LF1

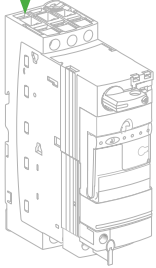

LUA LB1

DB414653.eps

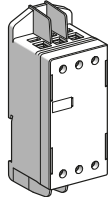

LA9LB920

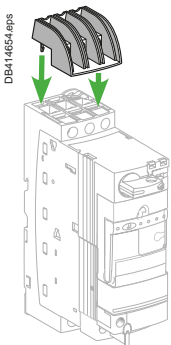

LU9SP0

PB113926.eps



LU9ET1S

Short-circuit current limiter block

To be connected in series and upstream of a TeSys U starter-controller . It increases its ability to withstand the short circuit current from 50 kA to 100 or 130 kA under 400 V.

Principle: under the action of a short-circuit, the opening of two contacts of each phase of the limiter creates a resistive arc. The current then decreases to a value tolerable by a TeSys U power base.

Limiter blocks and accessories

Description	Breaking capacity Iq (kA)		Mounting	Unit reference
	≤ 440 V	690 V		
Limiter-disconnector (1 x LUAFL1 cartridge supplied)	130	70	Direct on power base	LUALB1 ⁽¹⁾
Limiter cartridge for LUALB1	100	35	Separate	LA9LB920 ⁽²⁾
Limiter cartridge for LUALB1	130	70	Limiter-disconnector	LUALF1

⁽¹⁾ Must be connected to one power base only.

⁽²⁾ Can be connected to multiple TeSys U power bases in parallel with limitation :

■ Total Ith max 63 A

■ Total nominal current 32 A from motor with simultaneous start (LA9LB920 could not withstand higher inrush peak current)

Phase barrier

Ensures a complementary electrical insulation between phases.

690 V AC network: compulsory.

440 V AC network: compulsory when assembling a UL508 type E compliant motor starter (Self Protected Starter).

Description	Use	Mounting	Reference
Phase separator	LUB or LU2B 12 or 120 LUB or LUB2B 32 or 320 LUA LB1	Live terminals L1, L2, L3	LU9SP0

Clip-in labels

Can be clipped on any TeSys U power base, on LU6M B0●● inverter block, and Linergy HK busbar system.

Marking accessory

Description	Sold by lot of	Reference per unit
Clip-in label 8 x 18 mm	100	LAD90

Safety-chain identification - Red label

The red sticker is dedicated to TeSys U LUCA, LUCB, LUCC, LUCD and LUCL control units.

Description	Reference per unit
Retrofit safety-chain identification sticker	LU9ET1S

Handles and components for rotary control

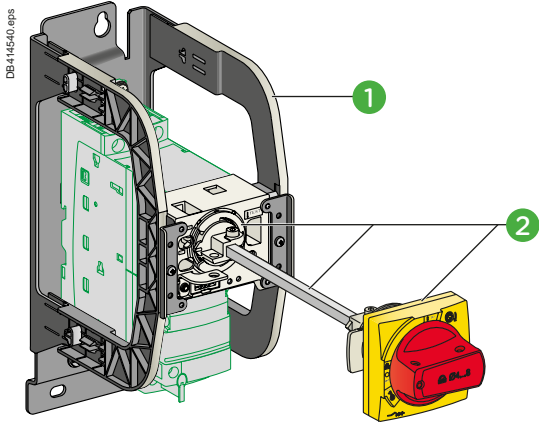

LU9APN21 mounting kit

Extended rotary handle

Allows a circuit breaker or a TeSys U starter-controller installed in back of an enclosure to be operated from the front panel.
 The rotary handle can be black or red/yellow, IP54 or IP65. It includes a function for locking the circuit breaker or the starter in the O (OFF) or I (ON) position (depending on the type of rotary handle) by means of up to 3 padlocks with a shank diameter of 4 to 8 mm.
 The extension shaft must be adjusted to the depth of the enclosure.
 The IP54 rotary handle is fixed with a nut (Ø22) to make it easier to assemble.

Mounting kit

- 1 TeSys U Power base bracket; its horseshoe shaped sides hold the rotary mechanism facing the original handle.
- 2 Mechanism, shaft and handle; the shaft enters the handle attached to the door during closing.

Long shaft

- to be cut to the required length. Equipped with a connection endpiece.

Shaft support plate for deep enclosure

- Provides horizontal guiding of the shaft, when the door is open.

Spacer base (retrofit accessory)

- Fixed on a side of the box, for heightening an GVA P●●● handle.

Handle

- Delivered as a single unit, to be fitted on a side of the enclosure.
- Note: references below are suitable for TeSys U power bases after 2004.*

"Laser Square" Tool

- On the principle of an angle extended with a laser beam, the "Laser Square" facilitates tracing the piercing marks on the door or the sides of an enclosure.

"Safety" stickers

- Marking: Electrical hazard, etc.

Description	Tripping indication	Reference
Mounting kit	Black handle, with error status, IP54	● LU9APN21
	Red handle, with error status, IP54	● LU9APN22
	Red handle, without error status, IP65	- LU9APN24
Separate elements	Long shaft = 315 mm	- GVAPA1
	Shaft (≥ 300 mm) support plate for deep enclosure	- GVAPK12
	Spacer base	- GVAPP1
	Black handle, IP54	● GVAPB54
	Red handle, IP54	● GVAPR54
	Black handle, IP65	● GVAPB65
	Red handle, IP65	● GVAPR65
Tool	"Laser square" plotting tool	GVAPL01
"Safety" stickers	French (x10)	GVAPSFR
	English (x10)	GVAPSEN
	German (x10)	GVAPSDE
	Spanish (x10)	GVAPSES
	Chinese (x10)	GVAPSCN
	Portuguese (x10)	GVAPSPT
	Russian (x10)	GVAPSRU
	Italian (x10)	GVAPSIT

TeSys U



GVAPA1 long shaft

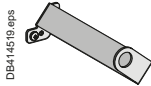

GVAPK12 shaft support plate for deep enclosure

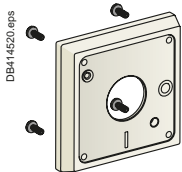

GVAPP1 spacer base (retrofit accessory)

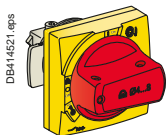

GVAPR54 red handle, IP 54

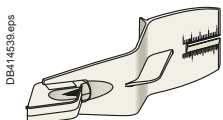

GVAPL01 "Laser square" plotting tool

Handles and components for MCC control drawers



MCC drawers (Motor Control Center)

The drawers are composed of:

- a fixed part, in the frame of the panel,
- a fully withdrawable part, integrating the protection, control and automation components.

With a height of 3/4/6/8/12/18/24/36 modules, they allow the assembling of motor protection/control feeders:

- Direct, one direction of rotation
- Direct, 2 directions of rotation
- Star-delta
- Dahlander (2 speeds)
- 2-speed, separate winding
- Motor drives from 0 to 500 kW
- Soft starters of 0 to 75 kW.

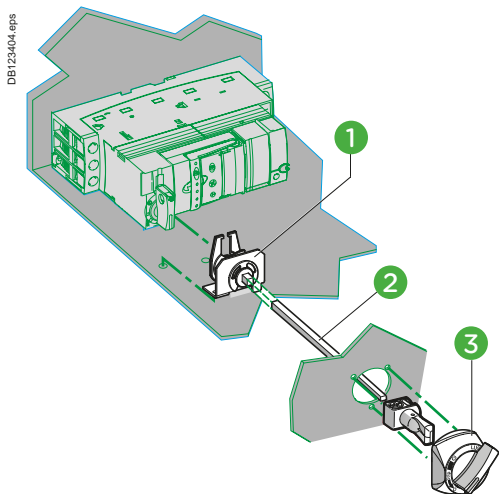

Mounting kit and handle for MCC drawer

Together, this provides manual control of a TeSys U starter-controller from the front face of the drawer.

As the clamping part on top of TeSys U control pad is open, the kit may be used on TeSys U power bases before 2005.

Mounting kit + small handle		
Description	Item	Reference
Handle with mounting kit for MCC drawer	1 + 2 + 3	LU9AP20

Technical Data for Designers

Contents

Characteristics.....	A4/38 to A4/45
Curves	A4/46 to A4/49
Selection	A4/50 to A4/51
Dimensions	A4/52 to A4/53
Schemes.....	A4/54 to A4/65
TeSys U and Altistart.....	A4/66 to A4/81

Environment			
Product certifications			UL, CSA, CCC, GOST, ASEFA. ABS, BV, DNV, GL, LROS. ATEX.
Conforming to standards			IEC/EN 60947-6-2, CSA C22-2 N° 14, Type E UL 508 type E: with phase barrier LU9 SP0
Rated insulation voltage (Ui)	Conforming to IEC/EN 60947-1, overvoltage category III, degree of pollution: 3	V	690
	Conforming to UL508, CSA C22-2 n°14	V	600
Rated impulse withstand voltage (Uimp)	Conforming to IEC/EN 60947-6-2	kV	6
Degree of protection Conforming to IEC/EN 60947-1 (protection against direct finger contact)	Front panel outside connection zone		IP 40
	Front panel and wired terminals		IP 20
	Other faces		IP 20
Protective treatment	Conforming to IEC/EN 60068		"TH"
	Conforming to IEC/EN 60068-2-30	Cycles	12
	Conforming to IEC/EN 60068-2-11	h	48
Ambient air temperature around the device	Storage	°C	-40...+85
	Operation	°C	Power bases and standard and advanced control units: -25...+70. (At temperatures above 60°C and up to 70°C, for starter-controller LUB32, leave a minimum gap of 9 mm between products). Power bases and multifunction control units: -25...+60. (At temperatures above 45 °C, leave a minimum gap of 9 mm between products. At temperatures above 55 °C and up to 60 °C, leave a gap of 20 mm between products.)
Maximum operating altitude		m	2000
Operating positions	In relation to normal vertical mounting plane		
Flame resistance	Conforming to UL 94		V2
	Conforming to IEC/EN 60695-2-12	°C	960 (parts supporting live components) °C 650
Environmental restrictions			Cadmium and silicone-free, recyclable
Shock resistance 1/2 sine wave = 11 ms	Conforming to IEC/EN 60068-2-27 ⁽¹⁾		Power poles open: 10 gn Power poles closed: 15 gn
Vibration resistance 5...300 Hz	Conforming to IEC/EN 60068-2-6 ⁽¹⁾		Power poles open: 2 gn Power poles closed: 4 gn ⁽²⁾
Resistance to electrostatic discharge	Conforming to IEC/EN 61000-4-2	kV	In open air: 8 - Level 3
		kV	On contact: 8 - Level 4
Immunity to radiated high-frequency disturbance	Conforming to IEC/EN 61000-4-3	V/m	10 - Level 3
Immunity to fast transient currents	Conforming to IEC/EN 61000-4-4	kV	All circuits except for serial link: 4 - Level 4
		kV	Serial link: 2 - Level 3
Immunity to dissipated shock waves	Conforming to IEC/EN 60947-6-2 Uc ~ 24...240 V, Uc --- 48...220 V Uc = 24 V ---	kV	Common mode
			Serial mode
			2
Immunity to conducted high-frequency disturbance	Conforming to IEC/EN 61000-4-6	V	10
Radiated emission and conducted	Conforming to CISPR 11 and EN 55011		Class A

(1) Without modifying the contact states, in the most unfavourable direction.

(2) 2 gn with Advantys STB or CANopen communication modules.

Power circuit connection characteristics

Connection to Ø4 mm screw clamp terminals

Power base, control unit or reverser block type			LUB 12 + LUCA or LUCB or LUCC or LUCD	LUB 32 + LUCA or LUCB or LUCC or LUCD	LUB 12 + LUCM	LUB 32 + LUCM	LU2B LU2M LU6M
Flexible cable without cable end	1 conductor	mm ²	2.5...10	2.5...10	2.5...10	2.5...10	2.5...10
	2 conductors	mm ²	1.5...6	1.5...6	1.5...6	1.5...6	1.5...6
Flexible cable with cable end	1 conductor	mm ²	1...6	1...6	1...6	1...6	1...6
	2 conductors	mm ²	1...6	1...6	1...6	1...6	1...6
Solid cable without cable end	1 conductor	mm ²	1...10	1...10	1...10	1...10	1...10
	2 conductors	mm ²	1...6	1...6	1...6	1...6	1...6
Screwdriver			Philips n° 2 or flat screwdriver: Ø6 mm				
Tightening torque		N.m	1.9...2.5	1.9...2.5	1.9...2.5	1.9...2.5	1.9...2.5

Control circuit connection characteristics

Connection to Ø3 mm screw clamp terminals

Flexible cable without cable end	1 conductor	mm ²	0.75...1.5	0.75...1.5	0.75...1.5	0.75...1.5	0.75...1.5
	2 conductors	mm ²	0.75...1.5	0.75...1.5	0.75...1.5	0.75...1.5	0.75...1.5
Flexible cable with cable end	1 conductor	mm ²	0.34...1.5	0.34...1.5	0.34...1.5	0.34...1.5	0.34...1.5
	2 conductors	mm ²	0.34...1.5	0.34...1.5	0.34...1.5	0.34...1.5	0.34...1.5
Solid cable without cable end	1 conductor	mm ²	0.75...1.5	0.75...1.5	0.75...1.5	0.75...1.5	0.75...1.5
	2 conductors	mm ²	0.75...1.5	0.75...1.5	0.75...1.5	0.75...1.5	0.75...1.5
Screwdriver			Philips n° 1 or flat screwdriver: Ø5 mm				
Tightening torque		N.m	0.8...1.2	0.8...1.2	0.8...1.2	0.8...1.2	0.8...1.2

Control circuit characteristics

Rated voltage of control circuit	~ 50/60 Hz	V	24...240	24...240	–	–	–
	≡	V	24...220	24...220	24	24	–
Voltage limits	≡ 24 V ⁽¹⁾	V	20...27	20...27	20...28	20...28	–
	Operation						
	~ 24 V	V	20...26.5	20...26.5	–	–	–
	~ or ≡ 48...72 V	V	~ 38.5...72, ≡ 38.5...93	–	–	–	–
	~ 110...240 V	V	~ 88...264	~ 88...264	–	–	–
	≡ 110...220 V	V	≡ 88...242	≡ 88...242	–	–	–
Drop-out	≡ 24 V	V	14.5	14.5	14.5	14.5	–
	~ 24 V	V	14.5	14.5	–	–	–
	~ or ≡ 48...72 V	V	29	29	–	–	–
	~ 110...240 V, ≡ 110...220 V	V	55	55	–	–	–
Typical consumption	≡ 24 V	mA	130	220	150	200	120
	I max while closing						
	~ 24 V	mA	140	220	–	–	2360
	~ or ≡ 48...72 V	mA	280	280	–	–	2300
	~ 110...240 V, ≡ 110...220 V	mA	280	280	–	–	1000
I rms sealed	≡ 24 V	mA	60	80	70	75	120
	~ 24 V	mA	70	90	–	–	⁽²⁾
	~ or ≡ 48...72 V	mA	35	45	–	–	⁽²⁾
	~ 110...240 V, ≡ 110...220 V	mA	35	25	–	–	⁽²⁾
Heat dissipation		W	2	3	1.7	1.8	–
Operating time	Closing	ms	24 V: 70; 48 V: 60; ≥ 72 V: 50		75	65	–
	Opening	ms	35	35	35	35	–
Resistance to micro-breaks		ms	3	3	3	3	–
Resistance to voltage dips	IEC/EN 61000-4-11		At least 70 % of Uc for 500 ms				–
Mechanical durability	In millions of operating cycles		15	15	15	15	–
Maximum operating rate	In operating cycles per hour		3600	3600	3600	3600	–

Main pole characteristics

Number of poles			3	3	3	3	–
Isolation conforming to IEC/EN 60947-1	Possible		Yes	Yes	Yes	Yes	–
	Padlocking		1 padlock with Ø6.9 mm shank				–
Rated thermal current		A	12	32	12	32	–
Rated operational current (Ue ≤ 440V)	To IEC/ Category AC-41		θ ≤ 70°C: 12 A	θ ≤ 70°C: 32 A	θ ≤ 55°C: 12 A	θ ≤ 55°C: 32 A	–
	EN 60947-6-2 Category AC-43		θ ≤ 70°C: 12 A	θ ≤ 70°C: 32 A	θ ≤ 55°C: 12 A	θ ≤ 55°C: 32 A	–
Rated operational voltage		V	690 ⁽³⁾	690 ⁽³⁾	690 ⁽³⁾	690 ⁽³⁾	–
Frequency limits	Of the operating current	Hz	40...60	40...60	40...60	40...60	–
Power dissipated in the power circuits	Operational current	A	3 6 9 12	18 25 32			–
	Power dissipated in all three poles	W	0.1 0.3 0.6 1.1	2.4 4.6 7.5			–
Rated breaking capacity on short-circuit		V	230 440 500 690				–
		kA	50 50 10 4				–
Total breaking time		ms	2 2 2				–
Thermal limit	With Isc max on 440 V	kA²s	90 120		90 120		–

(1) Voltage with maximum ripple of ± 10 %.

(2) No consumption sealed.

(3) For 690 V, use phase barrier LU9 SP0.

TeSys motor starters open version

TeSys U starter-controllers

Reversing power bases and auxiliary contacts

Specific characteristics of power bases LU2B and reverser blocks LU2M or LU6M

Duration of inrush phase	~ 50/60 Hz	ms	25
	---	ms	15
Maximum operating time	Without change of direction	ms	75
	With change of direction	ms	150

General characteristics of auxiliary contacts

Conventional thermal current (Ith)	For ambient temperature $\theta < 70\text{ }^\circ\text{C}$	A	5
Frequency of the operational current		Hz	Up to 400
Minimum switching capacity $\lambda = 10^{-8}$	U min	V	17
	I min	mA	5
Short-circuit protection	Conforming to IEC/EN 60947-5-1	A	gG fuse: 4
Short-time rating	Permissible for	1 s	A 30
		500 ms	A 40
		100 ms	A 50
Insulation resistance		mΩ	10
Non-overlap time	Guaranteed between N/C and N/O contacts	ms	2 (on energisation and on de-energisation)

Specific characteristics of auxiliary contacts built-into the power base

Linked contacts	Conforming to IEC/EN 60947-4-1		Each power base has 1 N/O contact and 1 N/C contact which are mechanically linked
Mirror contact	Conforming to IEC/EN 60947-1		The N/C contact fitted in each power base reliably represents the state of the power contacts (safety scheme)
Rated operational voltage (Ue)		V	Up to ~ 690; --- 250
Rated insulation voltage (Ui)	Conforming to IEC/EN 60947-5-1	V	690
	Conforming to UL, CSA	V	600

Specific characteristics of auxiliary contacts in modules LUF N, of auxiliary contacts LUA1 and of reverser blocks LU2M and LU6M

Rated operational voltage (Ue)		V	Up to ~ 250; --- 250
Rated insulation voltage (Ui)	Conforming to IEC/EN 60947-5-1	V	250
	Conforming to UL, CSA	V	250

Rated operational power of contacts Conforming to IEC/EN 60947-5-1

a.c. supply, categories AC-14 and AC-15

Electrical durability (valid for up to 3600 operating cycles/hour) on an inductive load such as the coil of an electromagnet: making current ($\cos \varphi = 0.7$) = 10 times the power broken ($\cos \varphi = 0.4$)

	V	24	48	115	230	400	440	600
1 million operating cycles	VA	60	120	280	560	960	1050	1440
3 million operating cycles	VA	16	32	80	160	280	300	420
10 million operating cycles	VA	4	8	20	40	70	80	100

d.c. supply, category DC-13

Electrical durability (valid for up to 1200 operating cycles/hour) on an inductive load such as the coil of an electromagnet, without economy resistor, the time constant increasing with the load.

	V	24	48	125	250
W		120	90	75	68
W		70	50	38	33
W		25	18	14	12

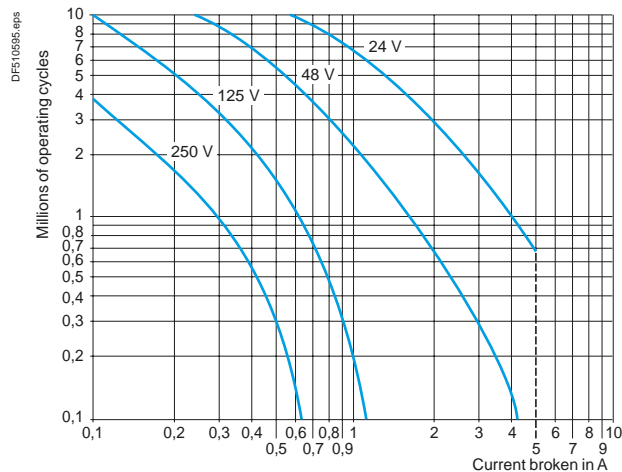
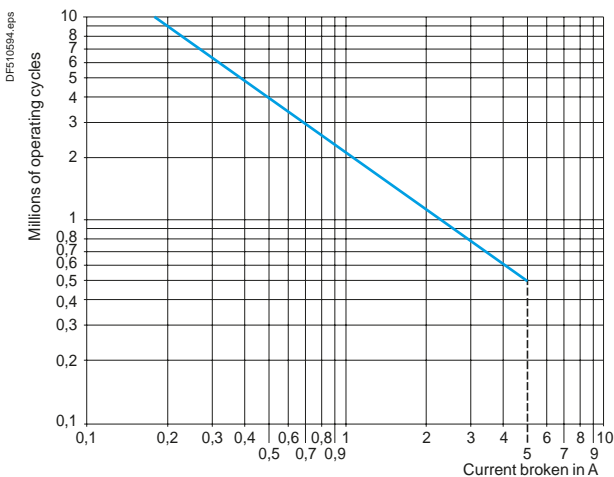

Characteristics of standard control units LUCA

Protection	Motor type		3-phase
	Conforming to standard		IEC/EN 60947-6-2, UL 508, CSA C22-2 n°14
Overload protection	Tripping class conforming to UL 508, IEC/EN 60947-6-2		10
	Frequency limits of the operational current	Hz	40...60
	Temperature compensation	°C	-25...+70
	Protection against phase imbalance		Yes
Short-circuit protection	Tripping threshold		13 x I _r max (max current setting)
	Tripping tolerance		±20 %

Characteristics of advanced control units LUCB, LUCC and LUCD

Control unit type		LUCB	LUCC	LUCD
Protection	Motor type	3-phase	Single-phase	3-phase
	Conforming to standard	IEC/EN 60947-6-2, UL 508, CSA C22-2 n°14	IEC/EN 60947-6-2, UL 508, CSA C22-2 n°14	IEC/EN 60947-6-2, UL 508, CSA C22-2 n°14
Overload protection	Tripping class conforming to UL 508, IEC/EN 60947-6-2	10	10	20
	Frequency limits of the operational current	Hz	40...60	40...60
	Temperature compensation	°C	-25...+70	-25...+55
	Protection against phase imbalance		Yes	–
Short-circuit protection	Tripping threshold	13 x I _r max.	13 x I _r max.	13 x I _r max.
	Tripping tolerance	±20 %	±20 %	±20 %

Characteristics of multifunction control units LUCM

Protection	Motor type		Parameters can be set: single-phase or 3-phase
	Conforming to standard		IEC/EN 60947-6-2, UL 508
Overload protection	Tripping class conforming to UL 508, IEC/EN 60947-6-2		5, 10, 15, 20, 25, 30 (selectable)
	Frequency limits of the operational current	Hz	50...60
	Temperature compensation	°C	-25...+55
Communication interface for terminal on enclosure door	Physical interface		RS 485 multi-drop
	Connections		RJ45 on front panel
	Protocol		Modbus RTU
	Maximum transmission speed	bit/s	19 200 (self-configuration up to this value)
	Maximum return time	ms	200
Display	Type		LCD, 2 lines of 12 characters
	Language version		Multilanguage (English, French, German, Italian, Spanish)
	Precision		±5 %
	Resolution		1 % of I _r
Auxiliary supply	External type	V	~ 24, with maximum ripple of ±10 %.
	Heat dissipation	W	0.8

Configuration table for protection devices and alarms on multifunction control units LUCM

	Tripping	Alarm	Adjustment of tripping threshold		Adjustment of time before tripping		Adjustment of alarm threshold	
	Factory setting	Factory setting	Range	Default value	Range	Default value	Range	Default value
Overcurrent	Activated ⁽¹⁾	–	3...17 I _r	14.2	–	–	–	–
Overload	Activated ⁽¹⁾	Activated	0.5...32 A ⁽²⁾	I _r min	Class: 5...30	5	10...100 % of the thermal state	85 %
Earth fault	Activated	Activated	0.2...5 I _r min	0.3 I _r min	0.1...1.2 s	0.1 s	0.2...5 I _r min	0.3 I _r min
Phase imbalance	Activated	Activated	10...30 %	10 %	0.2...20 s	5 s	10...30 %	10 %
Torque limitation	Deactivated	Deactivated	1...8 I _r	2 I _r	1...30 s	5 s	1...8 I _r	2 I _r
No-load running	Deactivated	Deactivated	0.3...1 I _r	0.5 I _r	1...200 s	10 s	0.3...1 I _r	0.5 I _r
Long starting time	Deactivated	Deactivated	1...8 I _r	I _r	1...200 s	10 s	1...8 I _r	I _r

Configuration of additional functions on multifunction control units LUCM

	Factory setting	Setting range
Reset	Manual	Manual, automatic or remote
Time before reset	120 s	1...1000 s
Type of load	3-phase motor	3-phase motor, single-phase motor
	Self-cooled	Self-cooled, force cooled
Language	English	English, French, German, Italian, Spanish
Display	Average current	Average current, thermal state of motor, current in phase 1 / 2 / 3, earth leakage current, phase imbalance, cause of last 5 faults

(1) This function cannot be deactivated.

(2) The setting range depends on the rating of the control unit used.

TeSys motor starters - open version

TeSys U starter-controllers

Limiter-disconnector, current limiter, thermal overload alarm function module and thermal overload fault signalling modules

Characteristics of limiter-disconnector LUA LB1

Rated insulation voltage (Ui) conforming to standard IEC/EN 60947-1	V	690
Conventional thermal current (Ith) conforming to standard IEC/EN 60947-1	A	32
Operating threshold I rms	kA	50
Breaking capacity	V	440 690
	kA	130 70
Mounting		Directly on the upstream terminals of the starter-controller
Cabling		
Solid cable	1 conductor	mm ² 1.5...10
	2 conductors	mm ² 1.5...6
Flexible cable without cable end	1 conductor	mm ² 1...10
	2 conductors	mm ² 1...6
Flexible cable with cable end	1 conductor	mm ² 1...6
	2 conductors	mm ² 1...6
Screwdriver		Phillips n°2 or flat screwdriver Ø6 mm
Tightening torque	N.m	1.9...2.5

Characteristics of current limiter LA9 LB920

Rated insulation voltage (Ui) conforming to standard IEC/EN 60947-1	V	690
Conventional thermal current (Ith) conforming to standard IEC/EN 60947-1	A	63
Operating threshold I rms	A	1000
Breaking capacity	V	440 690
	kA	100 35
Mounting		Separate
Cabling		
Solid cable	1 conductor	mm ² 1.5...25
	2 conductors	mm ² 1.5...10
Flexible cable without cable end	1 conductor	mm ² 1.5...25
	2 conductors	mm ² 2.5...10
Flexible cable with cable end	1 conductor	mm ² 1.5...16
	2 conductors	mm ² 1.5...4
Screwdriver		Phillips n°2 or flat screwdriver Ø6 mm
Tightening torque	N.m	2.2

Characteristics of thermal overload alarm function modules LUF W10

Activation threshold		Fixed at 88 % of the thermal tripping state
Hysteresis between activation and switching off		5 %
Display		By LED on front panel
Supply		Powered by the control unit
Discrete output characteristics	Type	N/O contact
	AC-15	230 V max; 400 VA 100 000 operating cycles
	DC-13	24 V; 50 W 100 000 operating cycles
Conventional thermal current (Ith)	For ambient temperature $\theta < 70\text{ °C}$	A 2
Short-circuit protection	Conforming to IEC/EN 60947-5-1	A gG fuse: 2

Characteristics of thermal overload fault signalling and reset modules

Module type		LUF DH11	LUF DA01	LUF DA10
Fault signalling		By LED on front panel		
External power supply	V	~/- 24... 240		
Module consumption	mA	7 at - 24 1.1 at ~ 240		
Discrete outputs	Type	1 N/C+ 1 N/O	1 N/C	1 N/O
	AC-15	230 V max; 400 VA 100 000 operating cycles		
	DC-13	24 V; 50 W 100 000 operating cycles		
Conventional thermal current (Ith)	For ambient temperature $\theta < 70\text{ °C}$	A 2		
Short-circuit protection	Conforming to IEC/EN 60947-5-1	A gG fuse: 2		
Reset input	Conductor c.s.a.	mm ² 0.2 min		
	Length	m	500 (R = 50 Ω , L = 52.8 mH, Cp = 93 pF)	

Characteristics of motor load indication function module LUF V2

Analogue output			4 - 20 mA
Signal delivered			Value of I average/I _r ratio within the range of 0 to 2 for LUCB and LUCD Value of I average/I _r ratio within the range of 0 to 3 for LUC C
Load impedance	Minimum	kΩ	–
	Maximum	Ω	500
	Typical	Ω	100
Signal characteristics with advanced control unit	Precision		±6 %
Signal characteristics with multifunction control unit	Precision		±10 %
	Resolution		1 % of I _r
Supply			External ~ 24 V

Characteristics of AS-Interface communication modules ASILUF C5 and ASILUF C51

Module type		ASILUF C5	ASILUF C51
Product certification		AS-Interface V2.1 n° 52901	AS-Interface V2.1 n° 52303
AS-Interface profile		7.D.F.0	7.A.7.E
Ambient air temperature	°C	Operation -25...+70	
Cycle time	ms	5	10
Addressing		31 slaves	62 slaves
AS-Interface supply	V	29.5...31.5	
Current consumption	On the AS-Interface bus	mA	Normal operation: 25
		mA	Fault condition: 30
	On 24 V supply for the outputs	mA	200
Auxiliary supply	V	~ 24 ±30 %	
Number of outputs		2 dedicated to starter-controller coil operation	
Switching capacity of the solid state outputs		0.5 A/24 V (outputs protected against short-circuits)	
Indication/diagnostics		By 2 LEDs on front panel	

Characteristics of Modbus communication module LUL C03

Module type		LUL C031	LUL C033
Physical interface		RS 485 multi-drop	
Connections		RJ45 on front panel	
Protocol		Modbus RTU	
Maximum transmission speed	bit/s	19 200 (self-configuration up to this value)	
Maximum return time	ms	30	
Addressing		By switches: from 0...31	
Ambient air temperature	°C	Operation -25...+55	
Discrete inputs	Number	–	2 (to be assigned according to the configuration)
	Supply	V	~ 24
	Input current	mA	7
Nominal input values	Voltage	V	~ 24 (positive logic)
	Current	mA	7
Response time	Change to state 1	ms	10 (±30 %)
	Change to state 0	ms	10 (±30 %)
Input type		Resistive	
Solid state outputs	Number	3, of which 2 dedicated to starter-controller coil operation	
	Supply	V	~ 24
	Max. current	mA	500
Protection	gl fuse	A	1
Switching capacity		0.5 A/24 V	
Indication/diagnostics		By 3 LEDs on front panel	

TeSys motor starters open version

TeSys U starter-controllers

Function modules and communication modules

Characteristics of CANopen, Profibus DP and DeviceNet communication modules						
Communication module			Profibus DP LUL C07	CANopen LUL C08	DeviceNet LUL C09	
Services	Conformity class		NA	S 20 (Schneider Electric)	NA	
	Standard		Profibus DP	CIADS-301 V4.02 DR 303-2	IEC 62026-1, overvoltage category III, degree of pollution: 3	
	Profile		LVSG V1.0 MS (Motor Starter) and MMS (Motor Management Starter)	–	ODVA (Open DeviceNet Vendor Association) MS (Motor Starter)	
	Protocol		Profibus DP	CAN 2.0A (2B passive)	CAN 2.0A (2B passive)	
	Address		1...125	0...127 (by switches)	0...63	
Structure	Physical interface		9-way SUB-D male	9-way SUB-D female	"Open Style" connector	
	Binary rate		9600 Kbits/s...12 Mbits/s	10, 20, 50, 125, 250, 500 and 1000 Kbits/s (by switches)	125...500 kbaud	
	Cables		2 shielded twisted pairs			
Supply for the discrete outputs and control	~ 24 V	V	20...28			
	Current consumption	A	1.5 (max)			
	Protection by gl fuse	A	2			
Ambient air temperature		°C	Operation -25...+55			
Logic inputs	Number		2 (to be assigned according to the configuration)			
	Supply		V	~ 24		
	Input current		mA	7		
	Nominal input values	Voltage		V	~ 24 (positive logic)	
		Current		mA	7	
	Response time	Change to state 1		ms	10 (±30 %)	
		Change to state 0		ms	10 (±30 %)	
Input type			Resistive			
Discrete outputs	Number		3, of which 2 dedicated to starter-controller coil operation			
	Max. current		mA	500		
	Short-circuit protection			Yes		
	Switching capacity			0.5 A / ~ 24 V		
Indication/diagnostics			By 3 LEDs on front panel			

Characteristics of Advantys STB communication module LUL C15						
Physical interface			CAN			
Connections			Fire Wire			
Protocol			CAN 2.0 and CAN 2.B (passive mode)			
Transmission speed			kbit/s	800		
Addressing			Self-addressing			
Supply for the discrete outputs and control	~ 24 V		V	20...28		
	Current consumption		A	1.5 (max)		
	Protection by gl fuse		A	2		
Ambient air temperature		°C	Operation -25...+55			
Discrete inputs	Number		2 (to be assigned according to configuration)			
	Supply		V	~ 24		
	Input current		mA	7		
	Nominal input values	Voltage		V	~ 24 (positive logic)	
		Current		mA	7	
	Response time	Change to state 1		ms	10 (± 30 %)	
		Change to state 0		ms	10 (± 30 %)	
Input type			Resistive			
Discrete outputs	Number		3, of which 2 dedicated to starter-controller coil operation			
	Max. current		mA	500		
	Short-circuit protection			Yes		
	Switching capacity			0.5 A / ~ 24 V		
Indication/diagnostics			By 3 LEDs on front panel			

TeSys motor starters open version

TeSys U starter-controllers

Function modules and communication modules

Connection characteristics							
Module type			LUF W10, LUF DH11, LUF DA01 and LUF DA10	LUF V2	ASILUF C5 and ASILUF C51		
					Inputs and 24 V auxiliary supply	Outputs	
Connectors	Pitch		5.08	3.81	5.08	3.81	
Flexible cable without cable end	1 conductor	mm ²	0.2...1.5	0.14...1	0.2...1.5	0.14...1	
	2 identical conductors	mm ²	0.2...1	0.14...0.75	0.2...1	0.14...0.75	
Flexible cable with cable end	Without insulated ferrule	1 conductor	mm ²	0.25...1.5	0.25...1	0.25...1.5	0.25...1
		2 identical conductors	mm ²	0.25...1	0.25...0.34	0.25...1	0.25...0.34
	With insulated ferrule	1 conductor	mm ²	0.25...1.5	0.25...0.5	0.25...1.5	0.25...0.5
		2 identical conductors (Use a double cable end)	mm ²	0.5...1	0.5	0.5...1	0.5
Solid cable without cable end	1 conductor	mm ²	0.2...1.5	0.14...1	0.2...1.5	0.14...1	
	2 identical conductors	mm ²	0.2...1	0.14...0.5	0.2...1	0.14...0.5	
Conductor size	1 conductor		AWG 24... AWG 16	AWG 26... AWG 16	AWG 24... AWG 16	AWG 26... AWG 16	
Tightening torque		N.m	0.5...0.6	0.20...0.25	0.5...0.6	0.20...0.25	
Flat screwdriver		mm	3.5	2.5	3.5	2.5	
Module type			LUL C031, LUL C033, LUL C08 and LUL C15	LUFC 00	LUL C09		
					Inputs and 24 V auxiliary supply	Connection on the bus	
Connectors	Pitch		3.81	3.81	3.81	5 (Open Style) DeviceNet	
Flexible cable without cable end	1 conductor	mm ²	0.14...1	0.14...1	0.14...1	0.2...2.5	
	2 identical conductors	mm ²	0.14...0.75	0.14...0.75	0.14...0.75	0.5...1.5	
Flexible cable with cable end	Without insulated ferrule	1 conductor	mm ²	0.25...1	0.25...1	0.25...2.5	
		2 identical conductors	mm ²	0.25...0.34	0.25...0.34	0.25...1	
	With insulated ferrule	1 conductor	mm ²	0.25...0.5	0.25...0.5	0.25...0.5	0.25...2.5
		2 identical conductors (Use a double cable end)	mm ²	0.5	0.5	0.75	0.5...1.5
Solid cable without cable end	1 conductor	mm ²	0.14...1	0.14...1	0.14...1	0.2...2.5	
	2 identical conductors	mm ²	0.14...0.5	0.14...0.5	0.14...0.5	0.14...0.5	
Conductor size	1 conductor		AWG 26... AWG 16	AWG 26... AWG 16	AWG 26... AWG 16	AWG 24... AWG 16	
Tightening torque		N.m	0.20...0.25	0.20...0.25	0.20...0.25	0.5...0.6	
Flat screwdriver		mm	2.5	2.5	2.5	3.5	

Tripping curves for control units LUCA, LUCB, LUCD

Average operating times at 20 °C according to multiples of the setting current, tolerance : ± 20 %.

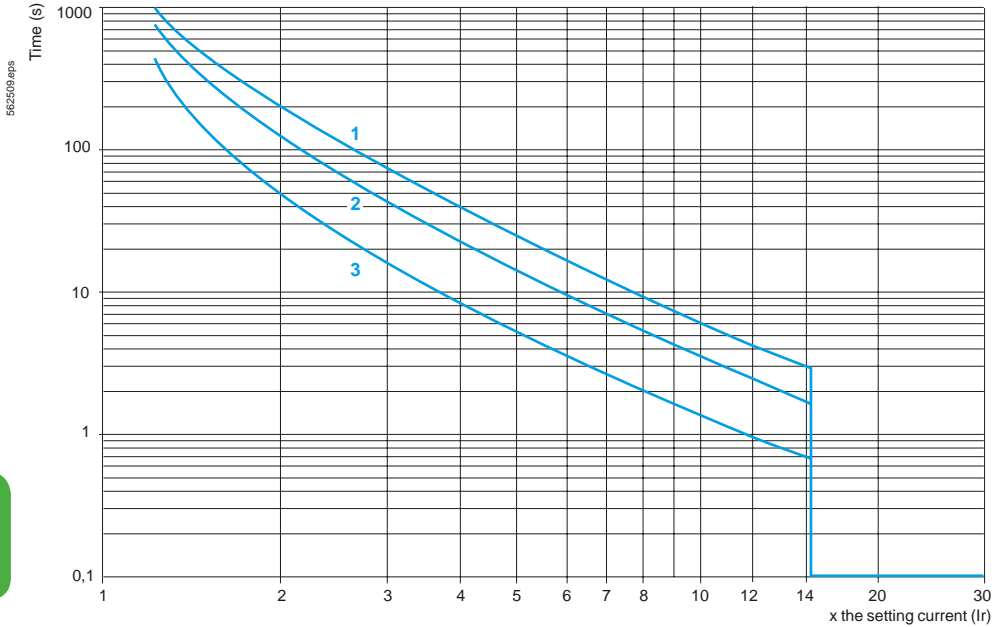

- 1 LUCD, 3 poles from cold state, class 20.
- 2 LUCA, LUCB, 3 poles from cold state, class 10.
- 3 LUCA, LUCB, LUCD, 3 poles from hot state.

Tripping curves for control units LUCC

Average operating times at 20 °C according to multiples of the setting current, tolerance : ± 20 %.

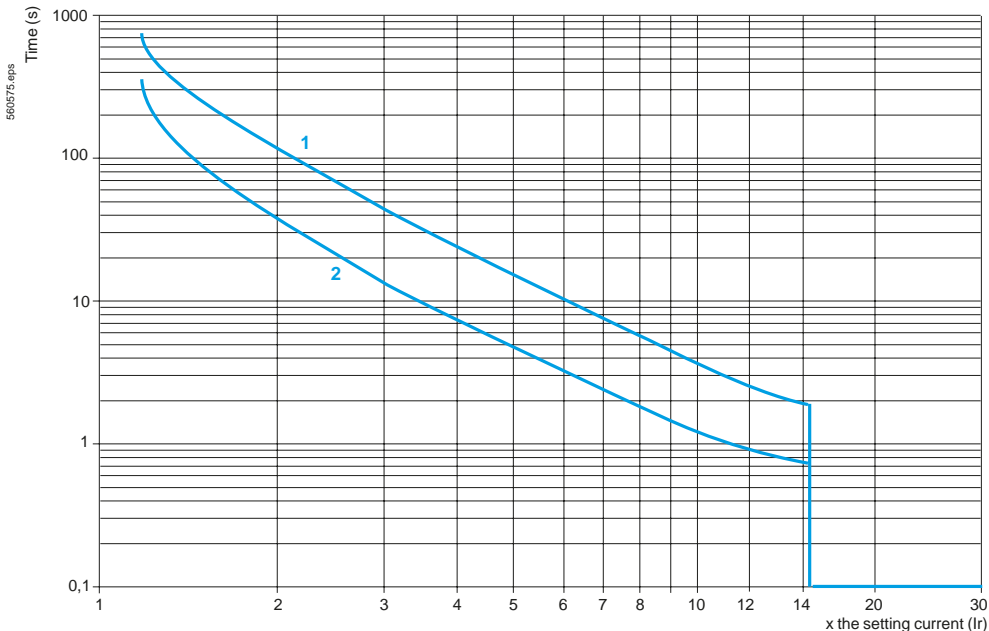

- 1 LUCC, single-phase, cold state.
- 2 LUCC, single-phase, hot state.

Tripping curves for control units LUCM

Cold state curves

Average operating times at 20 °C according to multiples of the setting current, tolerance : ± 20 %.

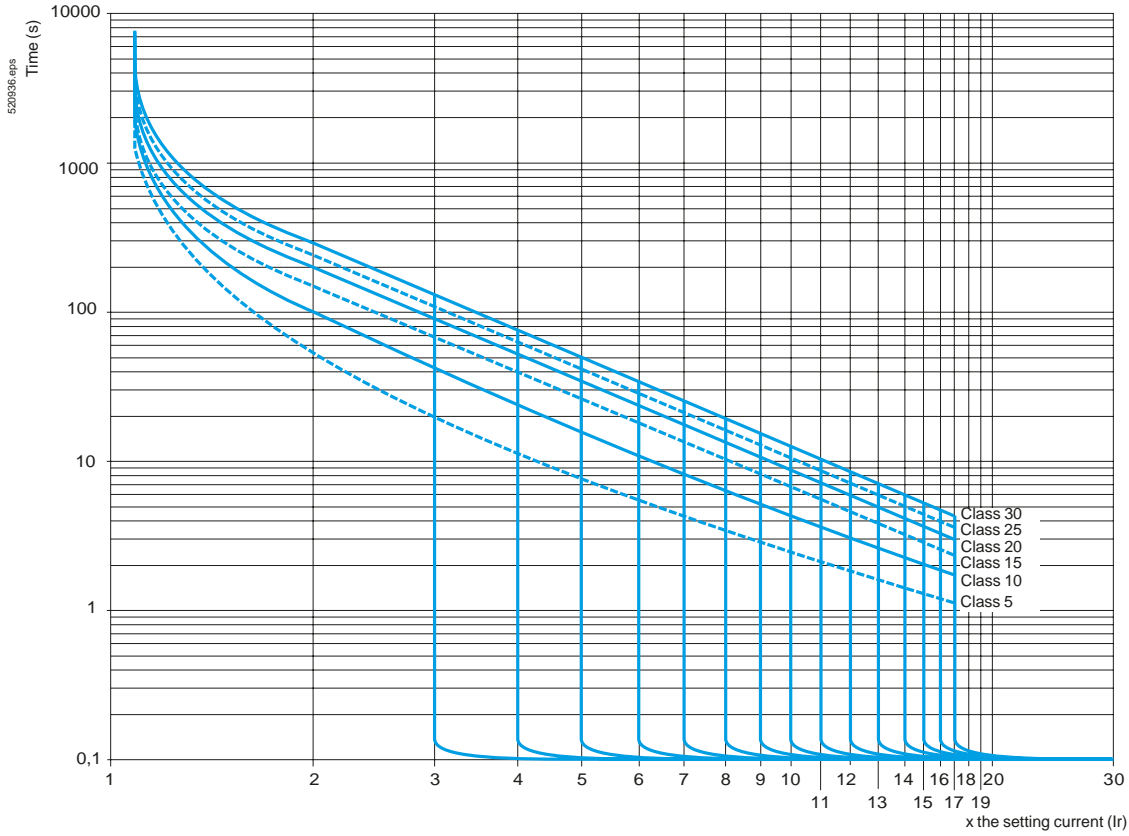

Tripping curves for control units LUCM

Hot state curves

Average operating times at 20 °C according to multiples of the setting current, tolerance : ± 20 %

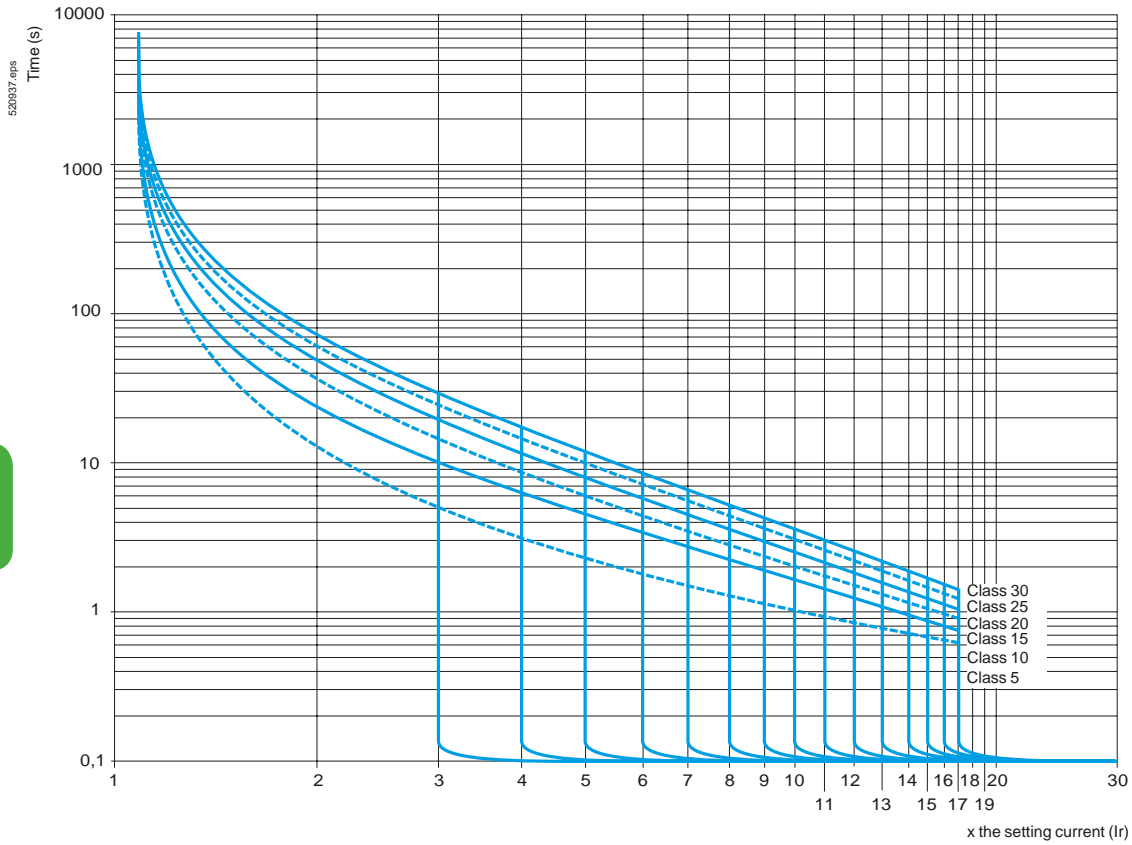

Current limitation on short-circuit

$U_e = 460 \text{ V}$

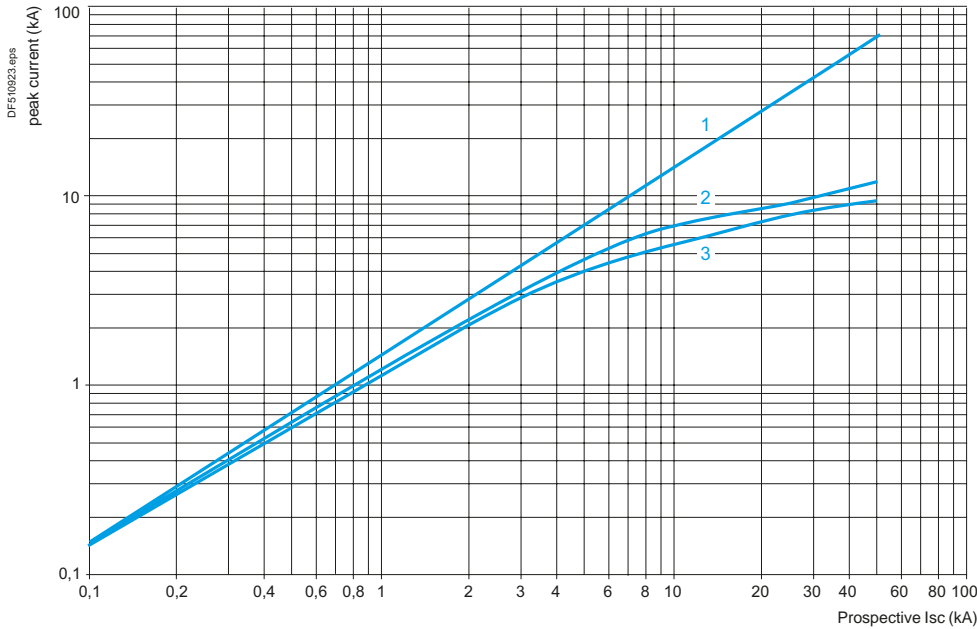

- 1 Maximum peak current
- 2 32 A power base
- 3 12 A power base

Thermal limit on short-circuit

$U_e = 460 \text{ V}$

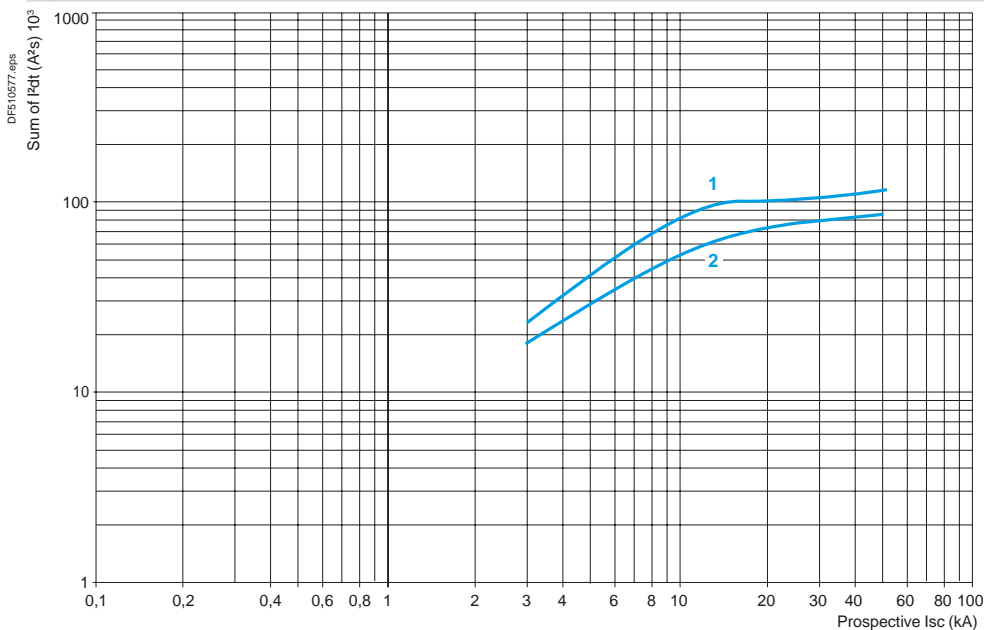

- 1 32 A power base
- 2 12 A power base

Use in category AC-41

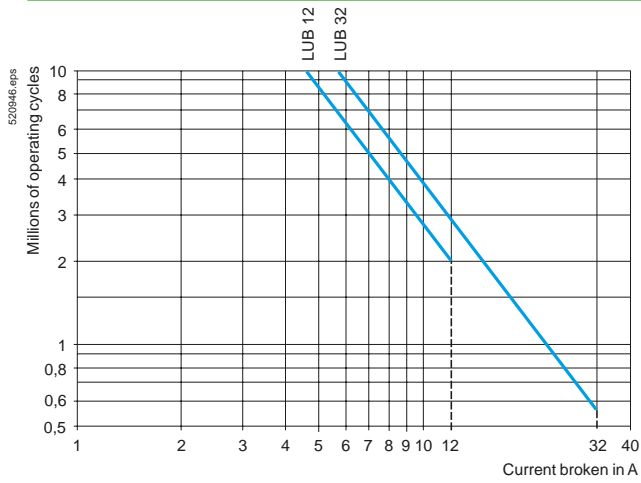

Use in category AC-43

Ue ≤ 440 V

Ue = 690 V

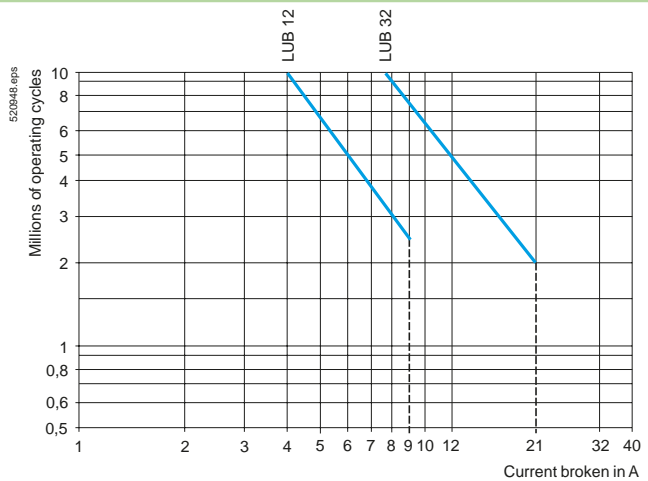
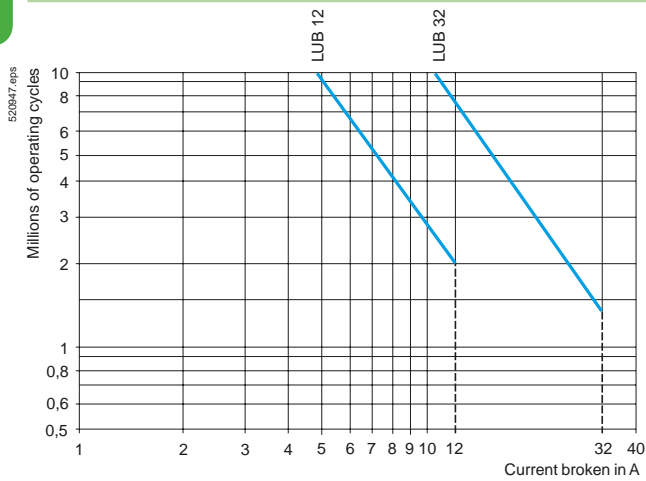

Use in category AC-44

Ue ≤ 440 V

Ue = 690 V

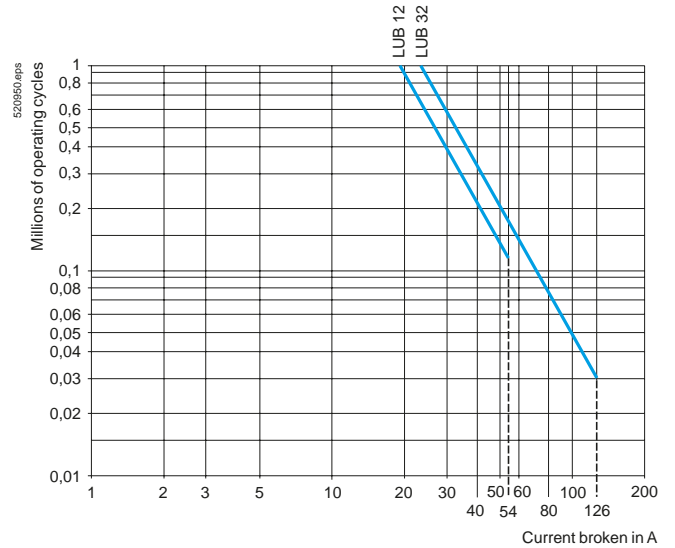
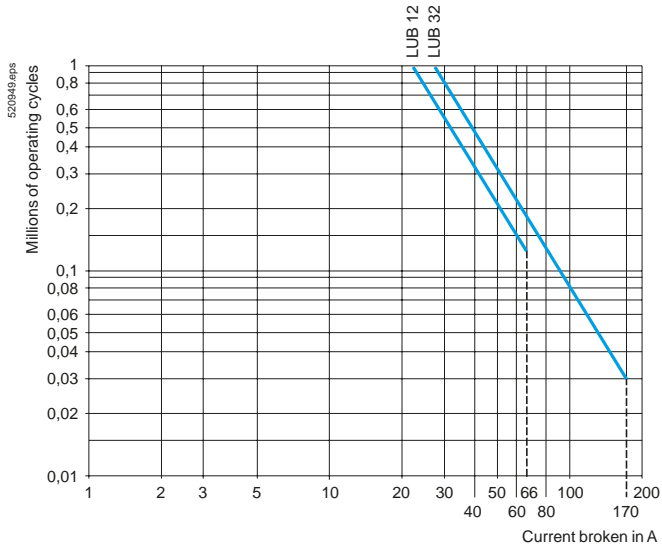

TeSys U

Dimensions

Starter-controllers

LUB: non-reversing

LU2B: reversing

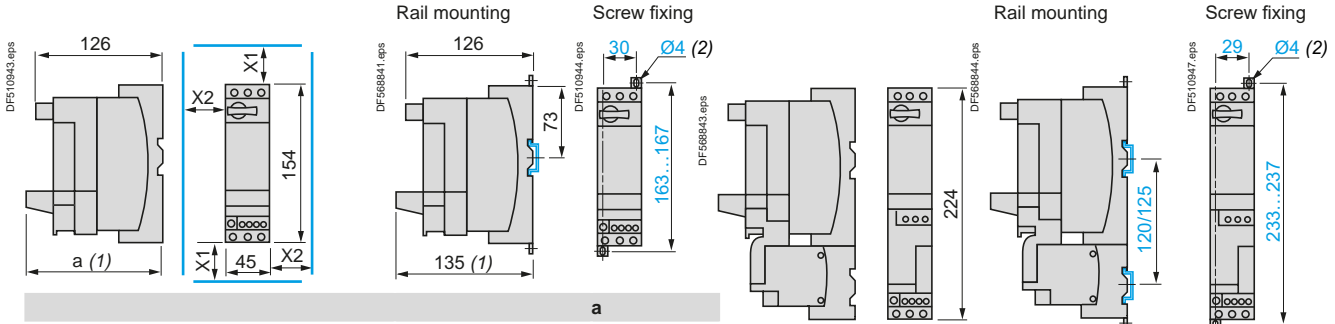

With Modbus module	135
With Advantys STB, CANopen, Profibus DP or DeviceNet modules	147

Minimum electrical clearance:
 X1 = 50 mm for Ue = 440 V and 70 mm for Ue = 500 and 690 V, X2 = 0

Reverser block for mounting separately from power base

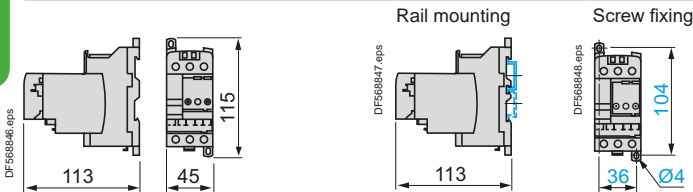

Sets of busbars and plug-in power sockets

GV2 G445 and GV2 G454

GV2 G... with terminal block GV1 G09

GV2 G245 and G254

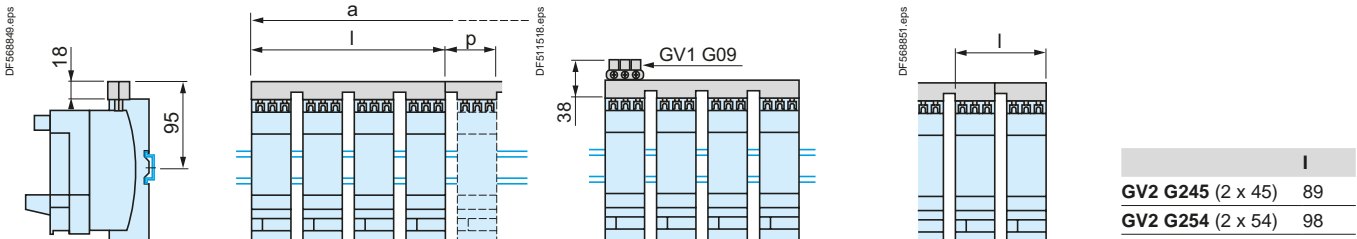

	I	P
GV2 G445 (2 x 45)	179	45
GV2 G454 (2 x 54)	206	54

	a			
Number of tap-offs	5	6	7	8
GV2 G445 (2 x 45)	224	269	314	359
GV2 G454 (2 x 54)	260	314	368	422

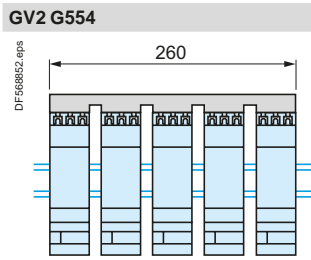

	I
GV2 G245 (2 x 45)	89
GV2 G254 (2 x 54)	98

	I
GV2 G345 (2 x 45)	134
GV2 G354 (2 x 54)	152

AK5 JB144

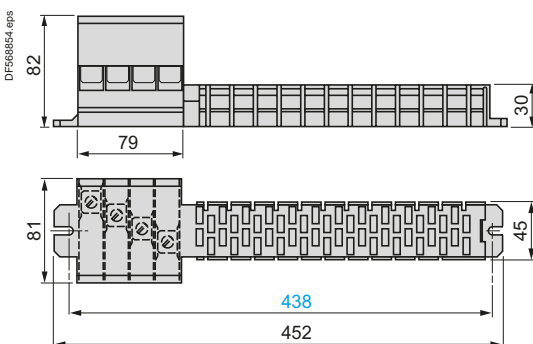

AK5 PC13, PC33, PC33L

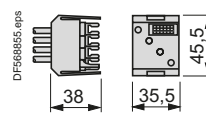

(1) Depth with communication module.
 (2) Retractable fixing lugs.

Dimensions (continued), mounting - TeSys U

TeSys motor starters - open version

TeSys U starter-controllers

Dimensions, mounting

Limiter-disconnector LUA LB1 Disconnector LUA LB10

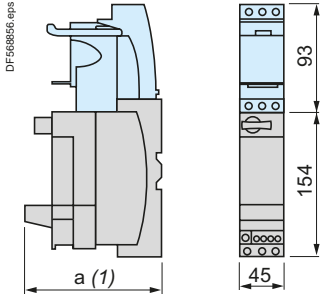

	a
With Modbus module	135
With Advantys STB, CANopen, Profibus DP or DeviceNet modules	147

Current limiter LA9 LB920

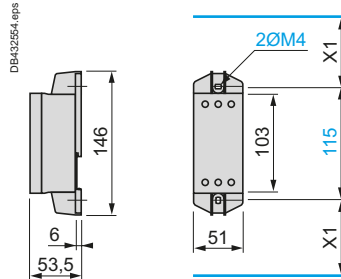

X1: Electrical clearance = 30 mm for $U_e \leq 690$ V

Door interlock mechanisms

LU9 APN21, LU9 APN22, LU9 APN24

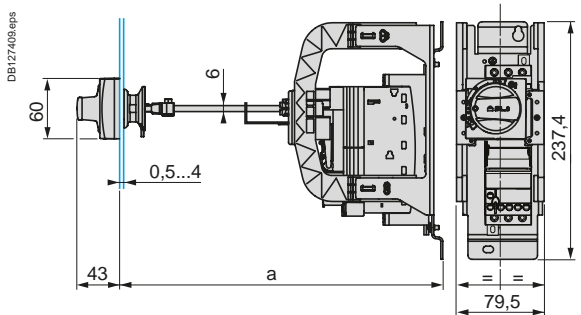

(1) For IP65 only.

	a	
	Mini	Maxi
LU9 APN●●	191	300
LU9 APN●● + GV APK12	300	483

Addressing consoles

XZ MC11

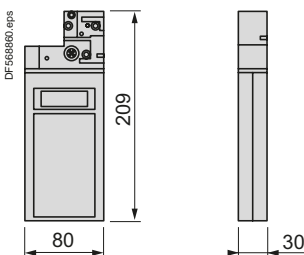

ASI TERV2

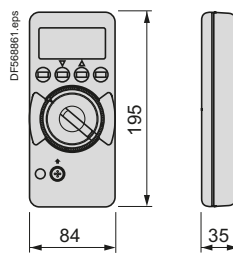

Splitter boxes

LU9 GC3 (Modbus) LU9 G02 and LU9 G03

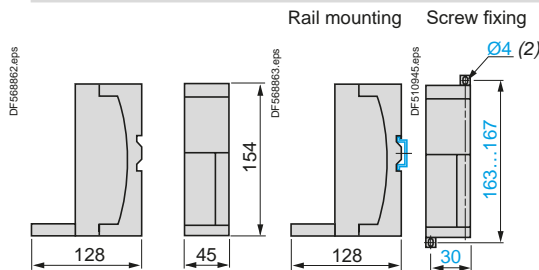

LU9 GC7 (Profibus DP)

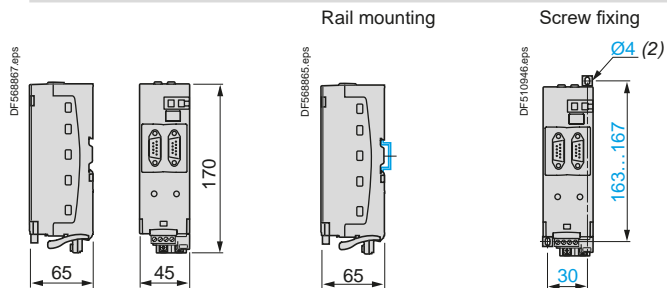

(1) Depth with communication module.

(2) Retractable fixing lugs.

Starter-controllers, 12 or 32 A with standard, advanced or multifunction control unit

LUB

Non-reversing

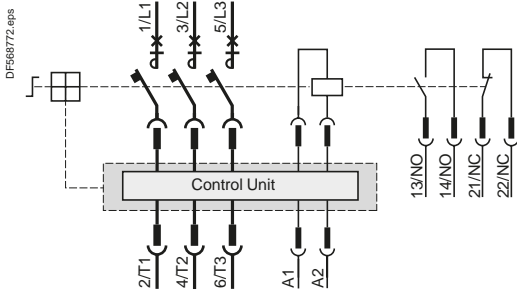

LU2B

Reversing

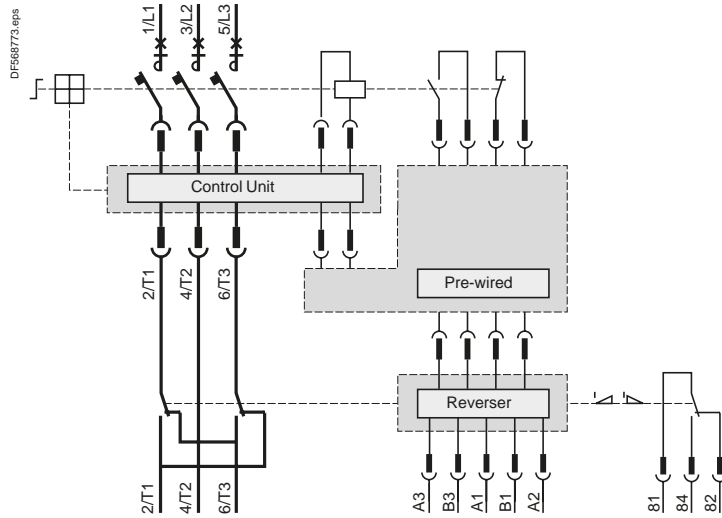

With control unit LUCC or LUCM

Connection of a single-phase motor

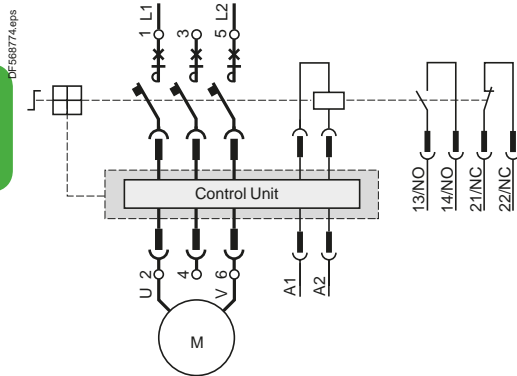

Control terminal block

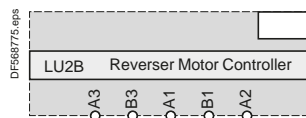

Reverser blocks

LU2M

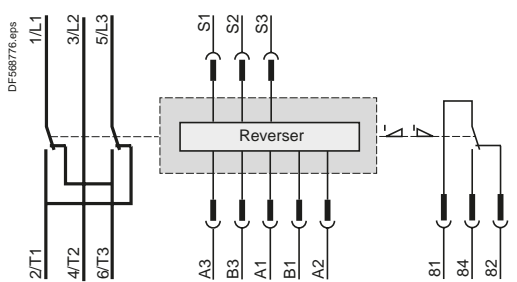

Control terminal block

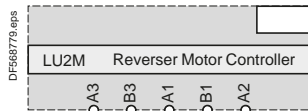

LU6M

Control terminal blocks

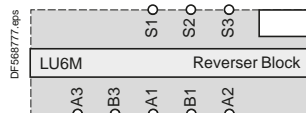

With pre-wired connector LU9 MRC

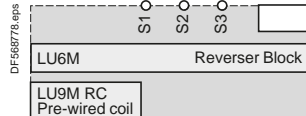

Basic scheme

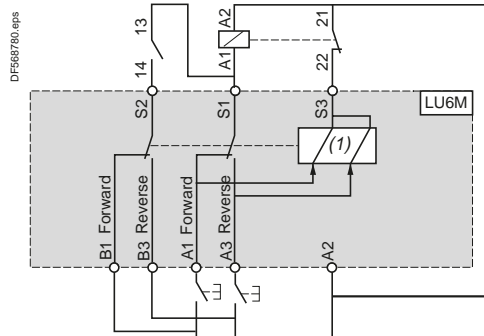

- S1 Start next stage
- S2 Electrical interlocking
- S3 Maintaining contact
- B1 Maintain forward running
- B3 Maintain reverse running
- A1 Pulse forward running
- A2 Common
- A3 Pulse reverse running
- (1) Electronically operated bistable electromagnet.

Add-on contact blocks

LUA1 C11

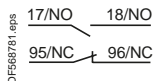

LUA1 C20

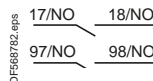

LUA8 E20

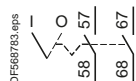

Add-on contact modules

LUFN 20

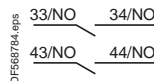

LUFN 11

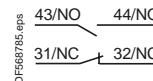

LUFN 02

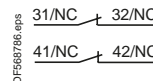

Control units

Standard control units LUCA

Basic scheme

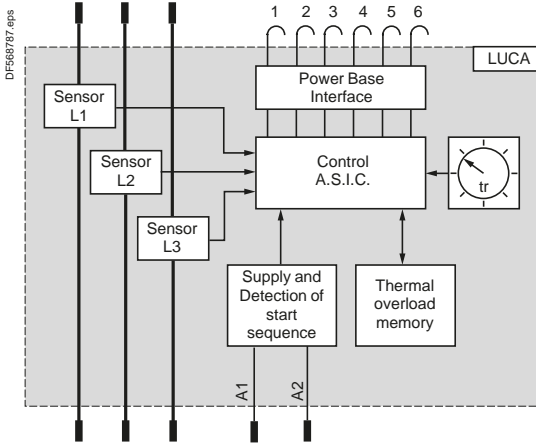

- 1 and 2 Trips
- 3 and 4 Electromagnet
- 5 Power base rating
- 6 N/C

Advanced control units LUCB, LUCC, LUCD

Basic schemehd

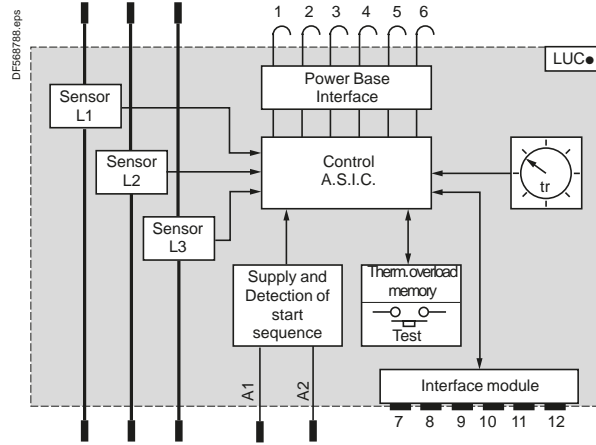

- 1 and 2 Trips
- 3 and 4 Electromagnet
- 5 Power base rating
- 6 N/C
- 7 Earth
- 8 Thermal status/Set
- 9 Reset mode/Reset
- 10 (Im/Ir)
- 11 Vc2
- 12 Vc1

Multifunction control units LUCM

Control terminal block

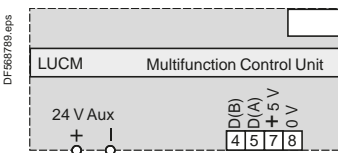

Basic scheme

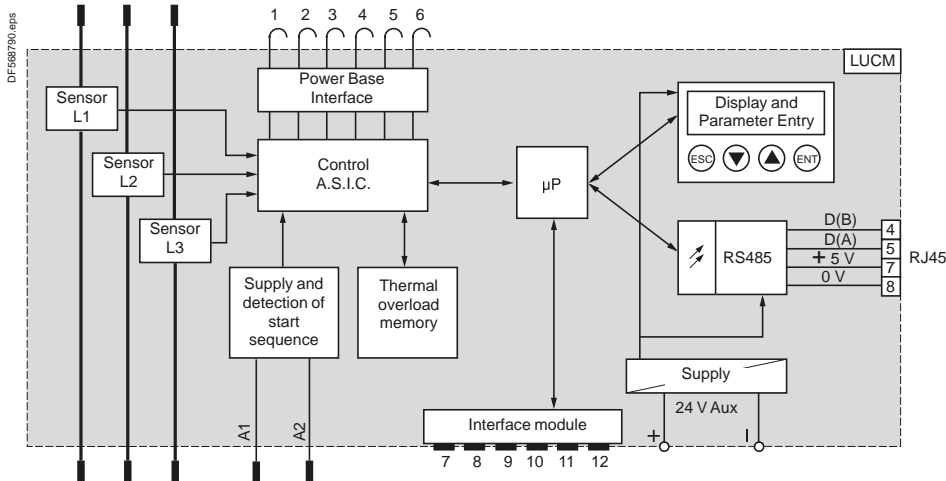

- 1 and 2 Trips
- 3 and 4 Electromagnet
- 5 Power base rating
- 6 N/C
- 7 Earth
- 8 N/C
- 9 Earth
- 10 (Im/Ir)
- 11 Rx/Tx
- 12 Vc1

Function modules

**Alarm
LUF W10**

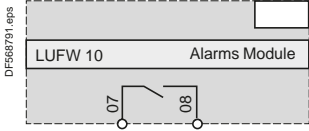

Basic scheme

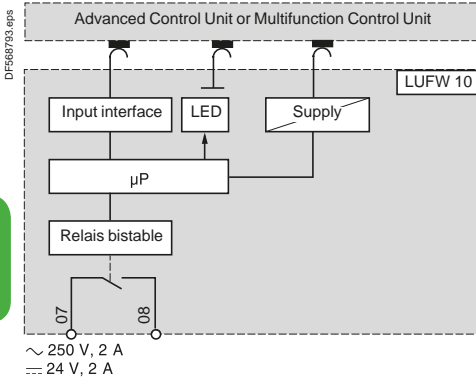

**Indication of motor load
LUF V2**

4-20 mA output

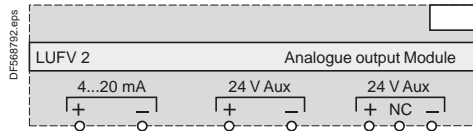

Basic scheme

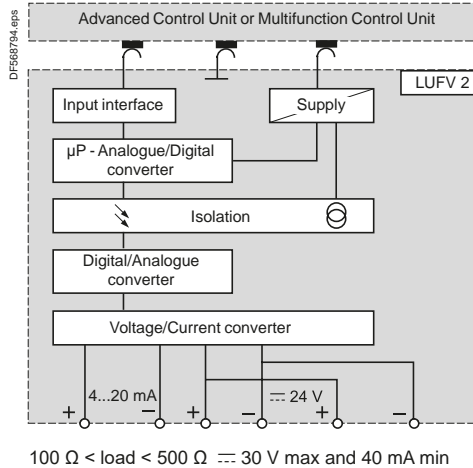

TeSys U

Communication modules

Communication modules ASILUF C5 and ASILUF C51

Without pre-wired coil connection

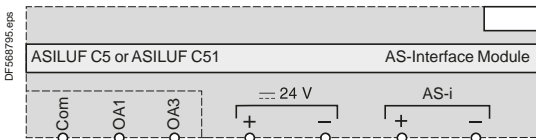

With pre-wired coil connection LU9B N11C

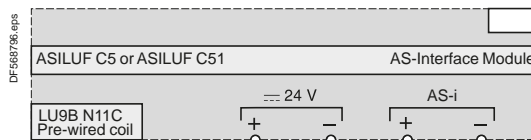

With pre-wired coil connection LU9M RC

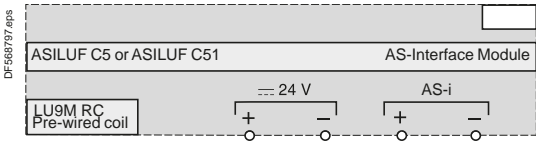

Basic scheme

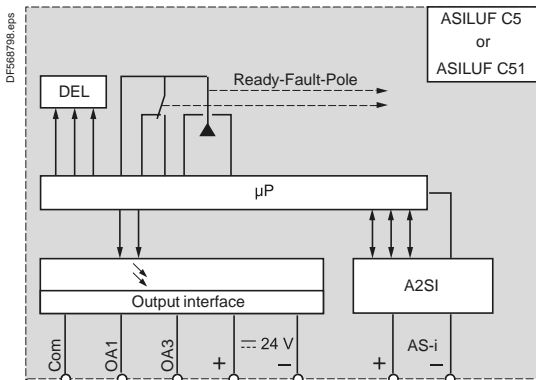

Communication modules (continued)

Modbus communication module LUL C031

Without pre-wired coil connection

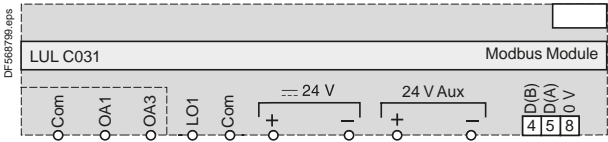

Modbus communication module LUL C033

Without pre-wired coil connection

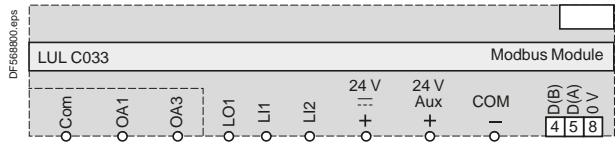

With pre-wired coil connection LU9B N11C

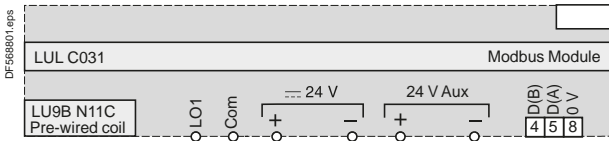

With pre-wired coil connection LU9B N11C

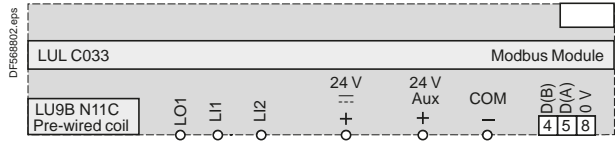

With pre-wired coil connection LU9M RC

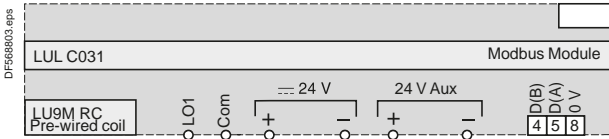

With pre-wired coil connection LU9M RC

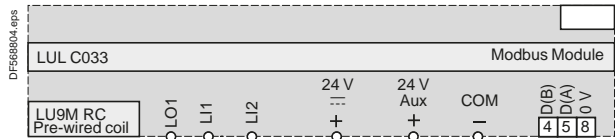

Basic scheme

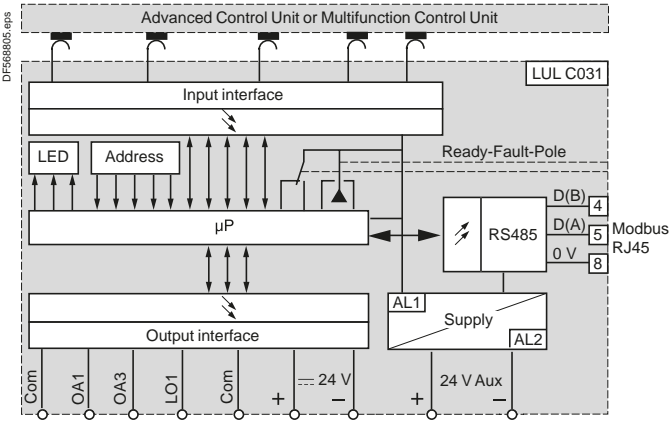

Basic scheme

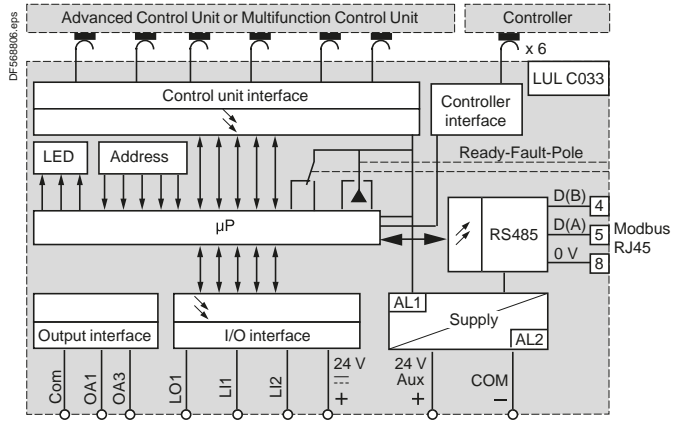

Communication modules (continued)

Profibus DP communication module LUL C07

Without pre-wired coil connection

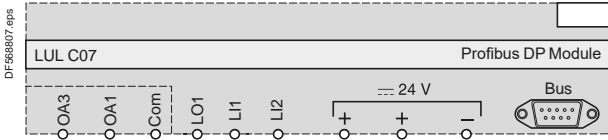

With pre-wired coil connection LU9B N11LC

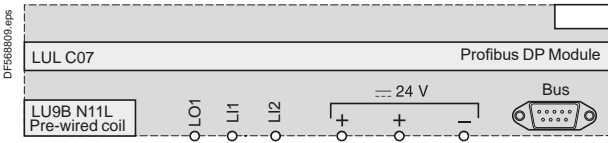

With pre-wired coil connection LU9M RC

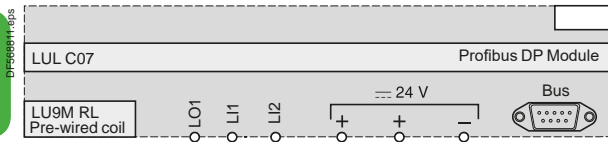

CANopen communication module LUL C08

Without pre-wired coil connection

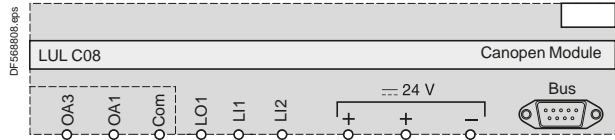

With pre-wired coil connection LU9B N11LC

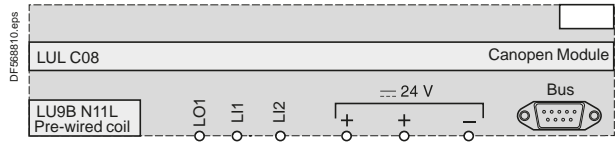

With pre-wired coil connection LU9M RC

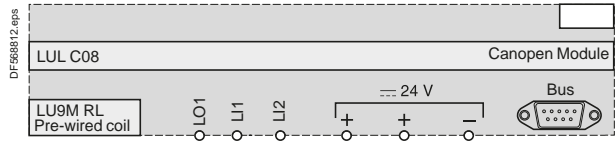

Basic scheme

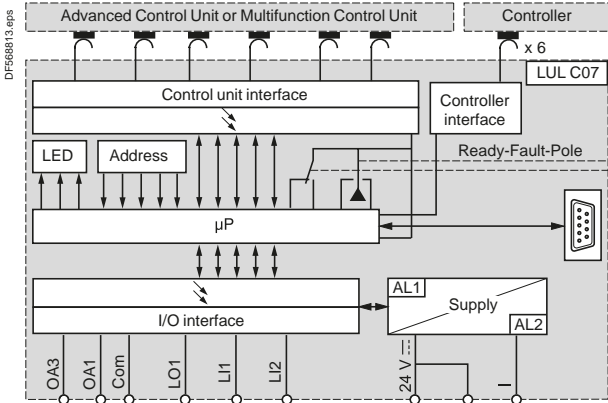

Basic scheme

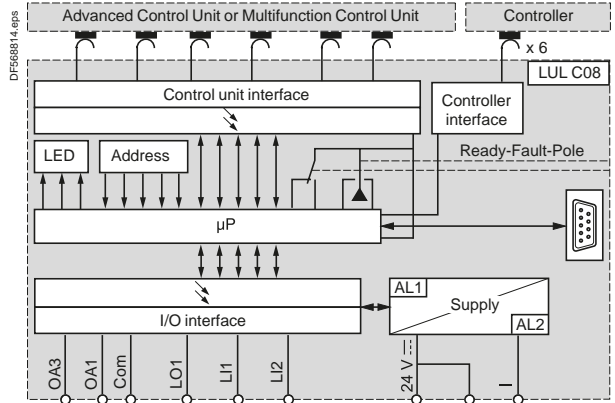

DeviceNet communication module LUL C09

Without pre-wired coil connection

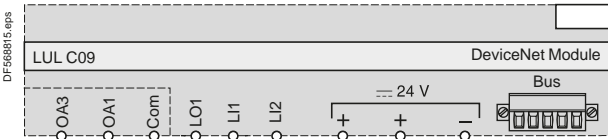

With pre-wired coil connection LU9B N11LC

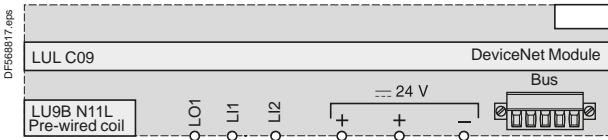

With pre-wired coil connection LU9M RL

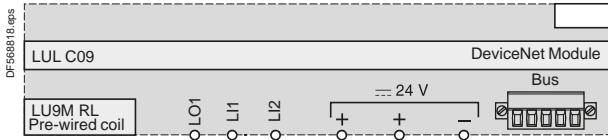

Basic scheme

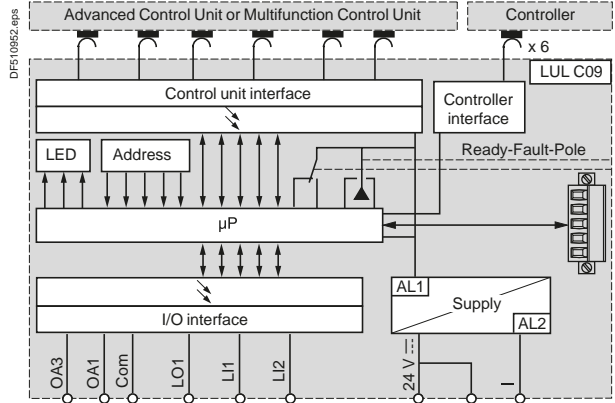

Communication modules (continued)

Advantys STB communication module LUL C15

Without pre-wired coil connection

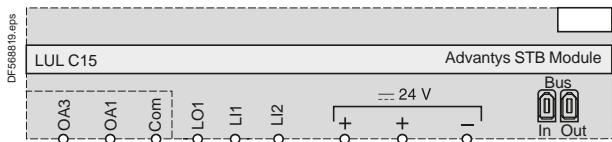

With pre-wired coil connection LU9B N11LC

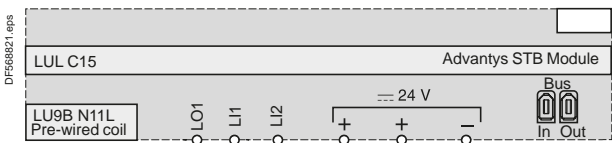

With pre-wired coil connection LU9M RC

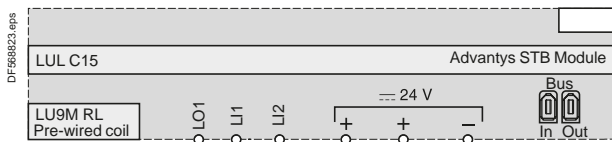

Basic scheme

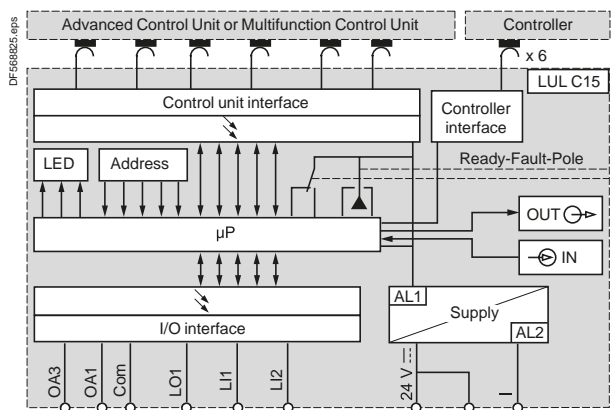

Profibus DP power supply module LU9 GC7

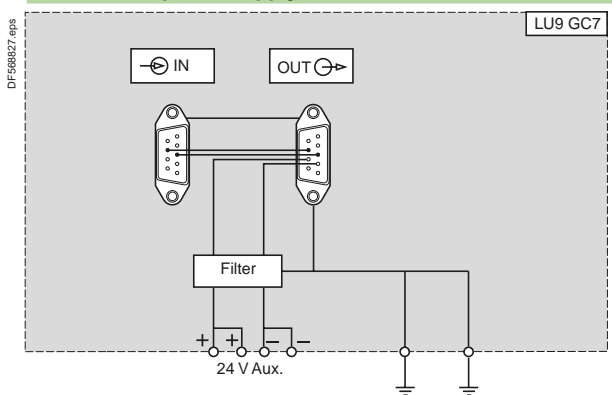

Parallel wiring modules

Without pre-wired coil connection

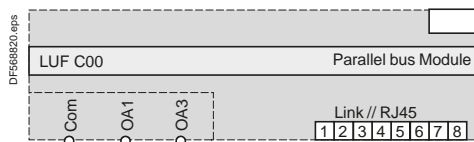

With pre-wired coil connection LU9B N11LC

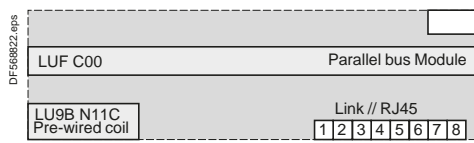

With pre-wired coil connection LU9M RC



Basic scheme

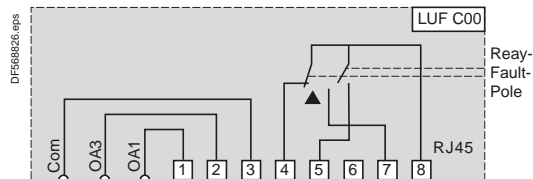

- 1 Forward running
- 2 Reverse running
- 3 Output common
- 4 Selector in position
- 5 Pole state
- 6 Reserved
- 7 Fault
- 8 Input common

Communication modules (continued)

Wiring hub and splitter boxes

Modbus hub LU9GC3

Parallel wiring splitter box LU9G02

Parallel wiring splitter box LU9G03

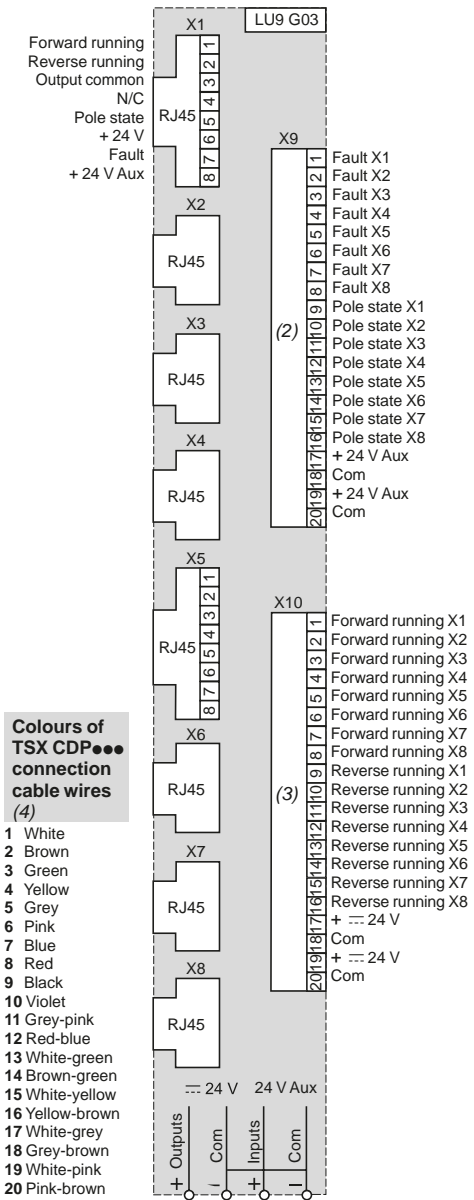
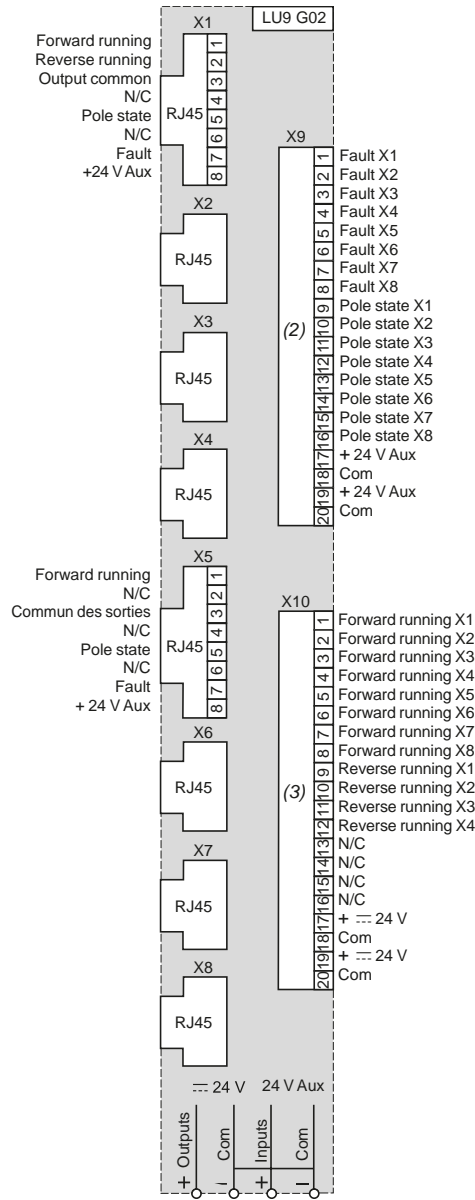
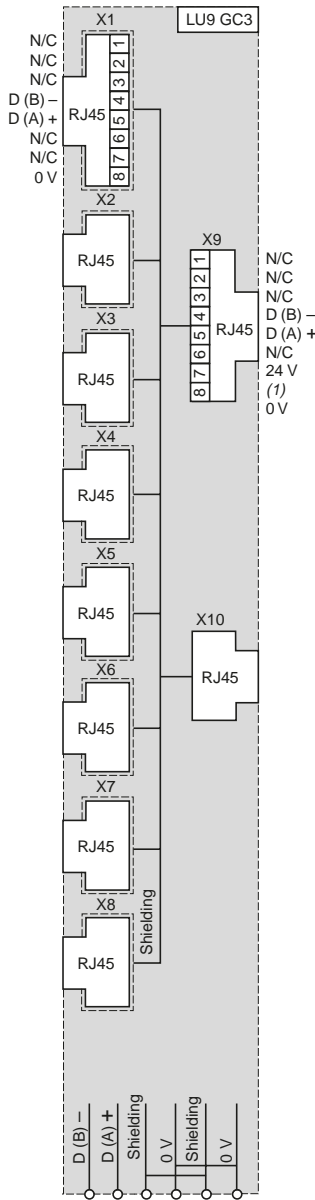

Colours of TSX CDP... connection cable wires (4)

- 1 White
- 2 Brown
- 3 Green
- 4 Yellow
- 5 Grey
- 6 Pink
- 7 Blue
- 8 Red
- 9 Black
- 10 Violet
- 11 Grey-pink
- 12 Red-blue
- 13 White-green
- 14 Brown-green
- 15 White-yellow
- 16 Yellow-brown
- 17 White-grey
- 18 Grey-brown
- 19 White-pink
- 20 Pink-brown

(1) Not connected on connectors X1 to X8. Only present on RJ45 IN and OUT connectors.

(2) 20-way HE10 input connector.

(3) 20-way HE10 output connector.

(4) Wire colours and corresponding HE10 connector pin numbers.

Gateways

LUF P1

LUF P7

LUF P9

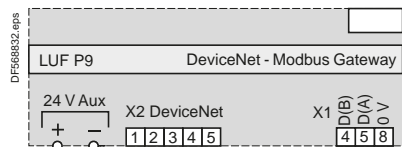
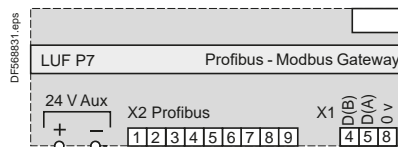
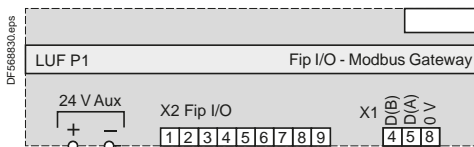

Data profile under AS-Interface				Standard LUCA	Advanced LUCB, CC, CD	Multifunction LUCM
Control unit present in the product						
Status		D0	Ready (available)			
		D1	Poles closed (running)			
Commands		D0	Start - forward running			
		D1	Start - reverse running			

Main registers accessible with Modbus, CANopen, Advantys STB, Profibus DP and DeviceNet communication modules.						
For other registers and for further information, please consult the User's Manual <i>Communication variables</i> on the website www.schneider-electric.com						
Control unit present in the product				Standard	Advanced	Multifunction
Marking	Register 0...Register 99	Words...Bits	Commercial reference, serial number, software version			
Log	Register 100...Register 450	Words...Bits	Fault log, Operating log, Log of last 5 trips			
Status	Register 451...Register 464	Words...Bits	Alarm signalling (bits), Fault signalling (bits)			
Values	Register 465...Register 473	Words	Irms phase 1, phase 2, phase 3. Motor load, thermal status Earth leakage current. Phase imbalance and phase failure			
	Register 474...Register 599	Words...Bits	Reserved			
Configuration	Register 600...Register 699	Words...Bits	Protection and alarm thresholds, fallback mode and reset mode			
Commands	Register 700...Register 714	Words...Bits	Commands			

Status and values	Register 452	Bit 0	Short-circuit fault			
		Bit 1	Overcurrent fault			
		Bit 2	Thermal overload fault			
	Register 455	Bit 0	Ready (available)			
		Bit 1	Poles closed			
		Bit 2	Fault			
		Bit 3	Alarms			
		Bit 4	Tripped ("TRIP" position)			
		Bit 5	Fault acknowledgement allowed			
		Bit 6	Reserved			
		Bit 7	Motor running			
		Bit 8	Motor current % (bit 0)			
		Bit 9	Motor current % (bit 1)			
		Bit 10	Motor current % (bit 2)			
		Bit 11	Motor current % (bit 3)			
		Bit 12	Motor current % (bit 4)			
		Bit 13	Motor current % (bit 5)			
		Bit 14	Reserved			
	Bit 15	Motor starting				
	Register 461	Bit 3	Thermal overload alarm			
Register 465	Word	Thermal status value				
Register 466	Word	Motor load value (Im/Ir)				

Configuration	Register 602	Bit 0	Manual reset on thermal overload fault			
		Bit 1	Remote reset on thermal overload fault			
		Bit 2	Automatic reset on thermal overload fault			
	Register 682	Value 0	Fallback mode validation			
		Value 1	Outputs OA1 and OA3 unchanged			
		Value 2	Outputs OA1 and OA3 forced to 0			
		Value 3	Outputs OA1 and OA3 unchanged, signalling existence of communication failure			
		Value 4	Outputs OA1 forced to 1 and OA3 unchanged			
Value 5	Outputs OA3 forced to 1 and OA1 unchanged					

Commands	Register 700	Bit 0	LO1 output command			
	Register 704	Bit 0	OA1 output command			
		Bit 1	OA3 output command			
		Bit 2	Reserved			
		Bit 3	Fault acknowledgement			
		Bit 4	Reserved			
		Bit 5	Trip test			
Bit 6...15	Reserved					

 Data accessible

TeSys motor starters - open version

TeSys U starter-controllers

Non-reversing

Non-reversing starter-controllers LUB

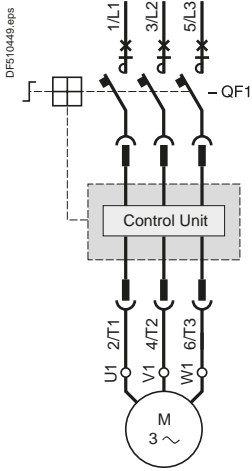

TeSys U

2-wire control via 2-position switch

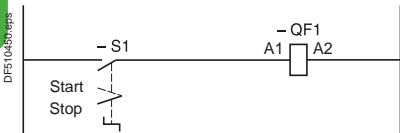

3-wire control, pulsed start with maintaining contact

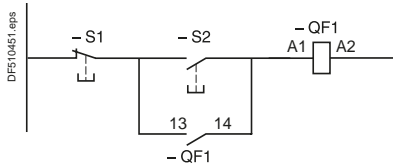

Connection of a motor load indicator module LUFV 2

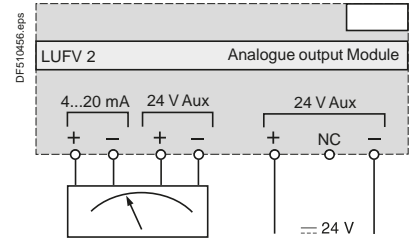

Connection of thermal overload fault signalling modules LUF DA10

Automatic reset

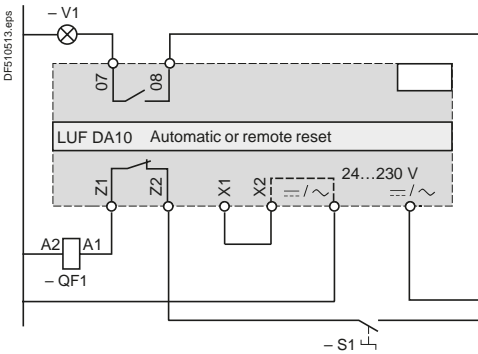

Remote reset

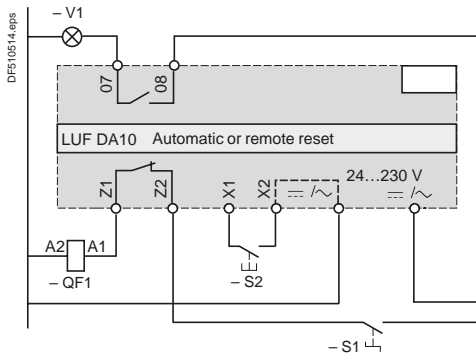

Control via Modbus communication module LUL C031

Without pre-wired coil connection

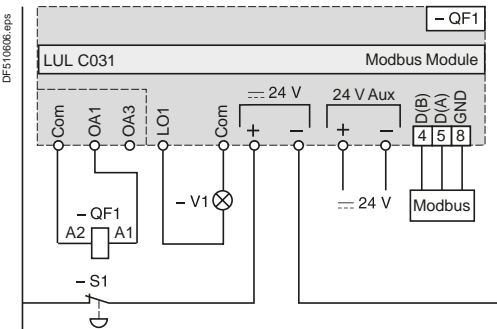

Control via Modbus communication module LUL C033

Without pre-wired coil connection

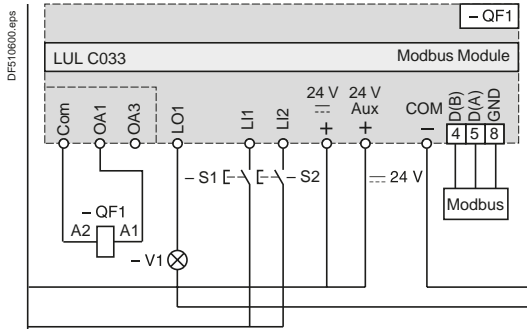

TeSys motor starters - open version

TeSys U starter-controllers

Non-reversing

Non-reversing starter controllers LUB (continued)

Control by communication modules ASILUF C5 and ASILUF C51

Without pre-wired coil connection

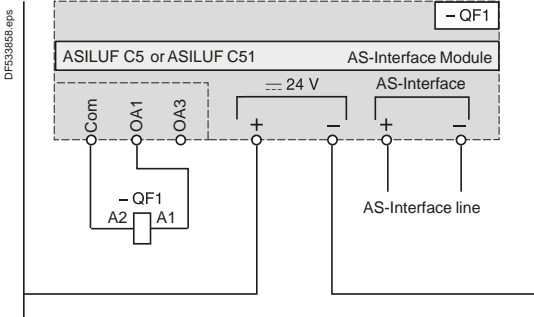

Without pre-wired coil connection With local control

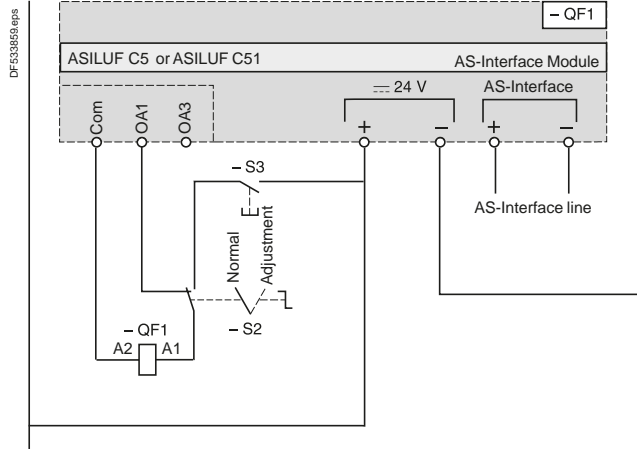

With pre-wired coil connection LU9B N11C

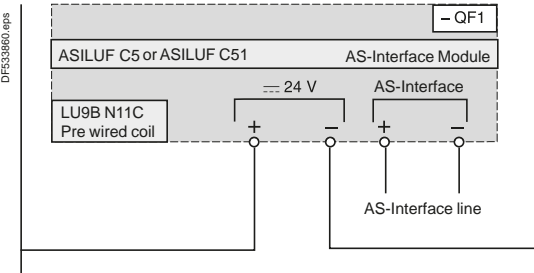

Without pre-wired coil connection With local control

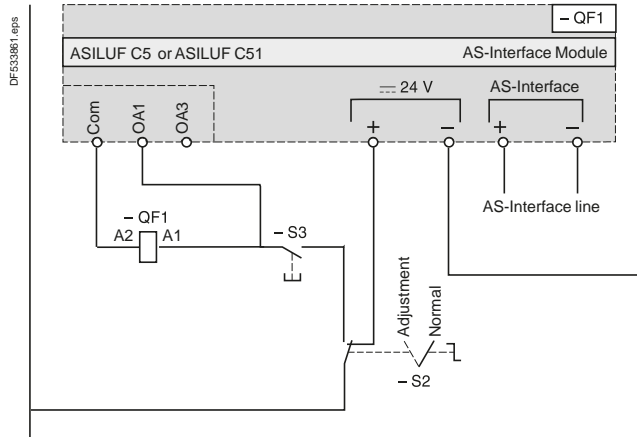

Without pre-wired coil connection With multifunction control unit LUCM

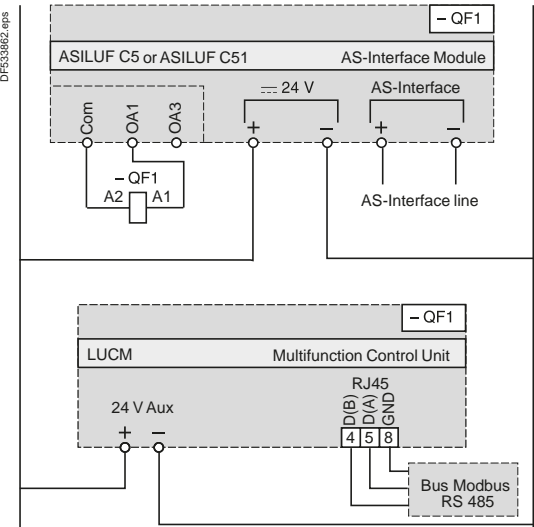

Reversing starter-controllers LUB

2-wire control via 3-position switch

3-wire control, pulsed start with maintaining contact

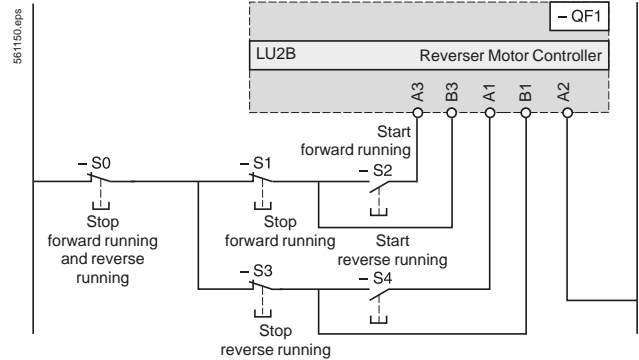
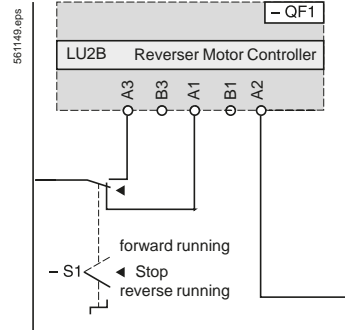
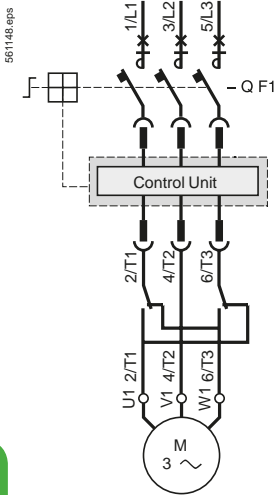

TeSys U

Control by communication modules ASILUF C5 and ASILUF C51

With pre-wired coil connection LU9M RC
With multifunction control unit LUCM

3-wire control, pulsed start with maintaining contact and limit switches

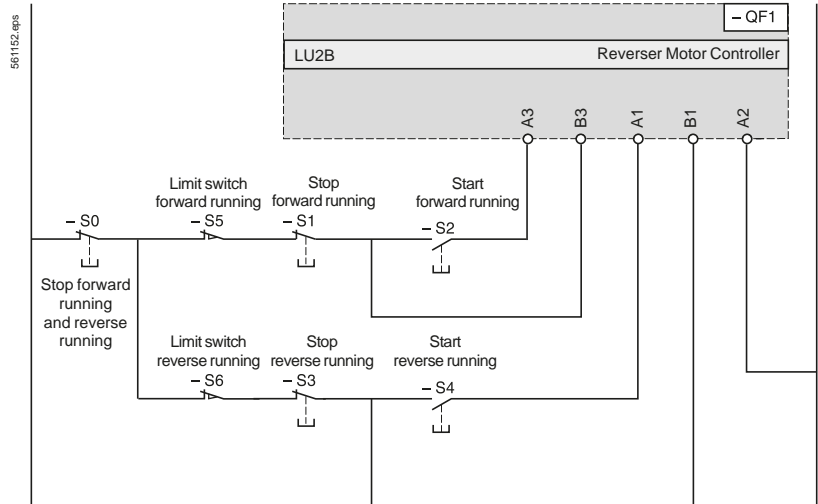
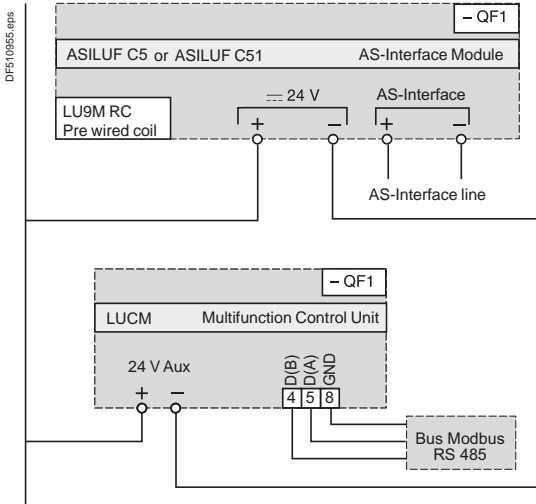

Control by communication modules ASILUF C5 and ASILUF C51

Without pre-wired coil connection
With running direction pilot lights and limit switches

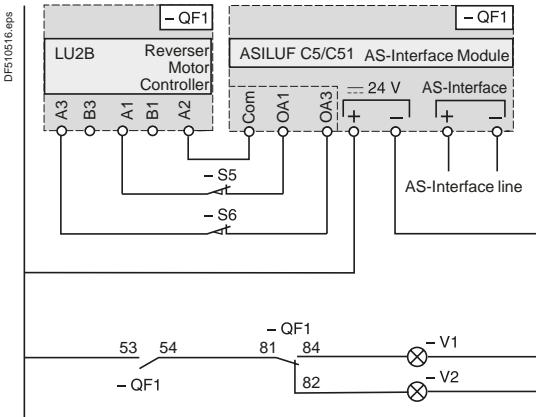

Reversing starter controllers LU2B (continued)

Control via Modbus communication module LUL C031

Without pre-wired coil connection. With local control

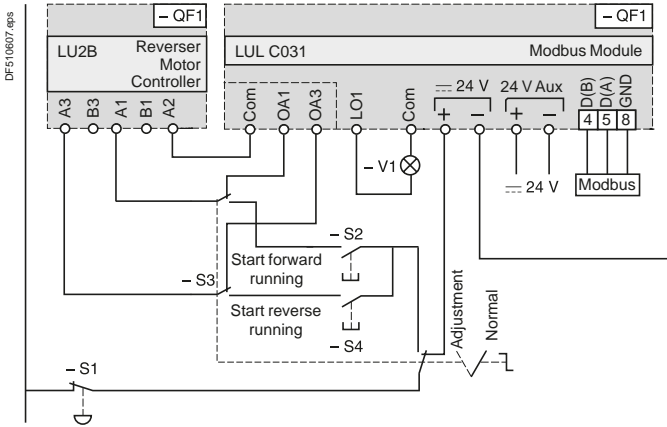

Control via Modbus communication module LUL C033

Without pre-wired coil connection. With local control

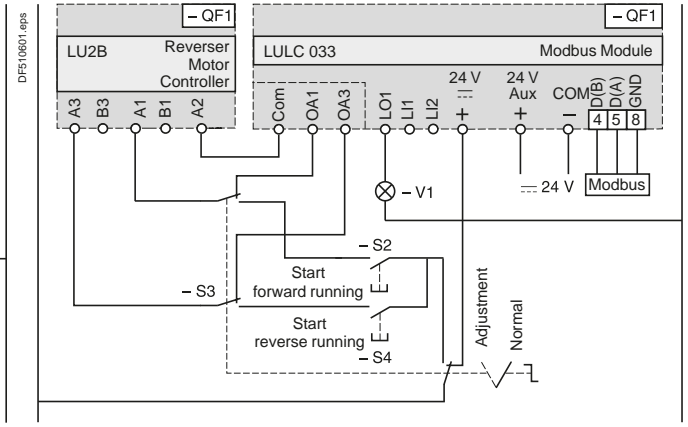

Reversing starter-controllers LUB + LU6M

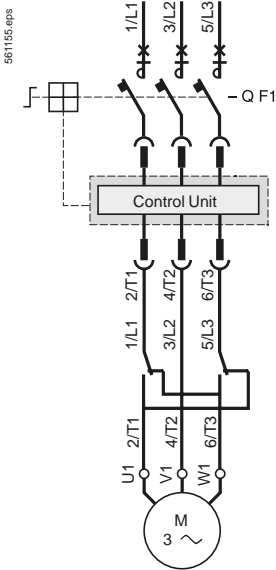

3-wire control, pulsed start with maintaining contact

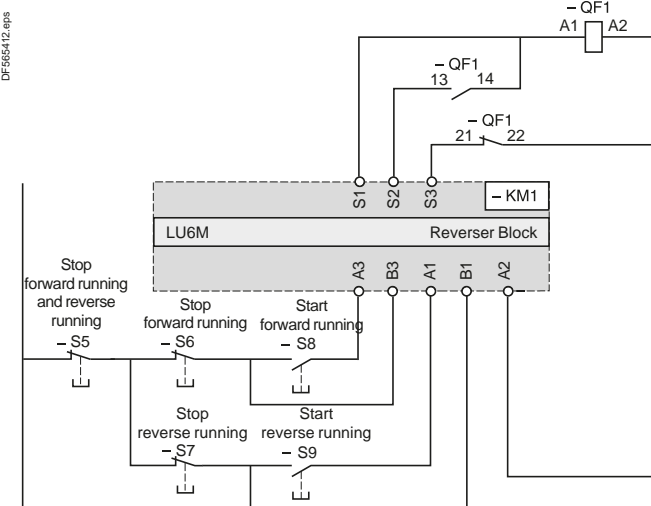

2-wire control via 3-position switch

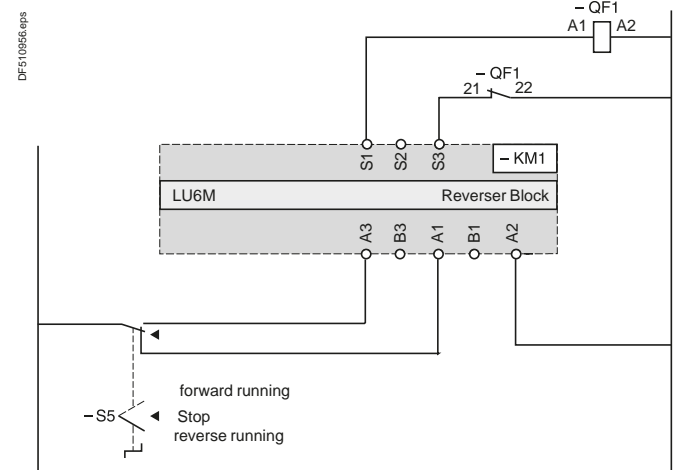

Soft starters for asynchronous motors

Altistart U01 and TeSys U

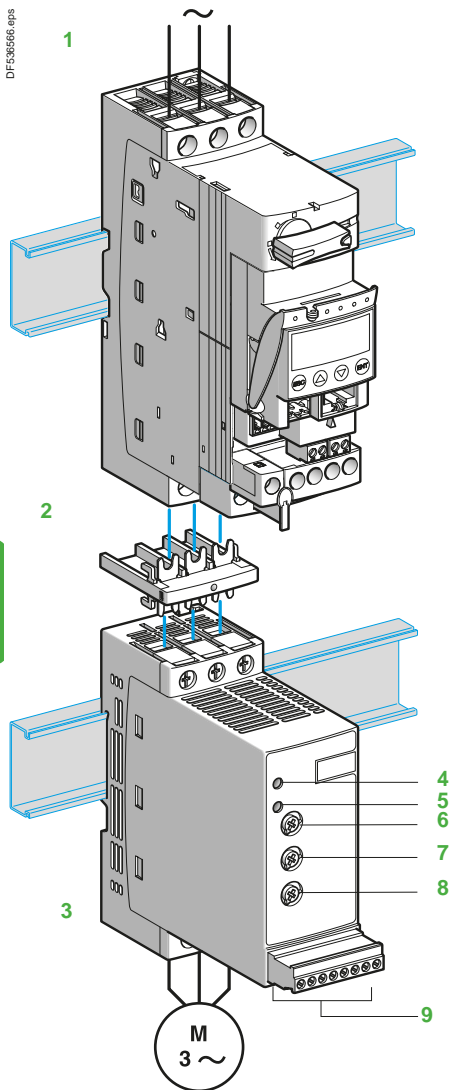

The Altistart U01 is a soft start/soft stop unit for asynchronous motors. It is designed primarily for combinations with **TeSys U** controller-starters.

When combined with a **TeSys U 1** controller by means of a connector **2**, the Altistart U01 **3** is a power option which provides the "Soft start/soft stop" function. The result is a unique, innovative motor starter.

Using the Altistart U01 starter enhances the starting performance of asynchronous motors by allowing them to start gradually, smoothly and in a controlled manner. It prevents mechanical shocks, which lead to wear and tear, and limits the amount of maintenance work and production downtime.

The Altistart U01 limits the starting torque and current peaks on starting, on machines which do not require a high starting torque.

The Altistart U01 is designed for the following simple applications:

- Conveyors
- Conveyor belts
- Pumps
- Fans
- Compressors
- Automatic doors and gates
- Small cranes
- Belt-driven machines, etc.

The Altistart U01 is compact and easy to install. It complies with standards IEC/EN 60947-4-2, carries UL, CSA, C-Tick, CCC certifications and CE marking.

■ ATSU 01N2●●LT soft start/soft stop units

- Control two phases of the motor power supply to limit the starting current and for deceleration
 - Internal bypass relay
 - Motor power ratings ranging from 0.75 kW to 15 kW
 - Motor supply voltages ranging from 200 V to 480 V, 50/60 Hz.
- An external power supply is required for controlling the starter.

Description

■ Altistart U01 soft start/soft stop units are equipped with:

- A potentiometer for setting the starting time **6**
- A potentiometer for setting the deceleration time **8**
- A potentiometer for adjusting the start voltage threshold according to the motor load **7**
- 1 green LED **4** to indicate that the unit is switched on
- 1 yellow LED **5** to indicate that the motor is powered at nominal voltage, if it is connected to the starter
- A connector **9**:
 - 2 logic inputs for Run/Stop commands
 - 1 logic input for the BOOST function
 - 1 logic output to indicate the end of starting
 - 1 relay output to indicate the starter has a power supply fault or the motor has reached a standstill at the end of the deceleration stage

Soft starters for asynchronous motors

Altistart U01 and TeSys U

Please consult the “TeSys U starters - open version” catalogue.

■ 2-wire control

The run and stop commands are controlled by a single logic input. State 1 of logic input LI2 controls starting and state 0 controls stopping.

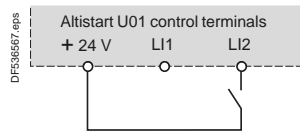

Wiring diagram for 2-wire control

■ 3-wire control

The run and stop commands are controlled by 2 different logic inputs.

Stopping is achieved when logic input LI1 opens (state 0).

The pulse on input LI2 is stored until input LI1 opens.

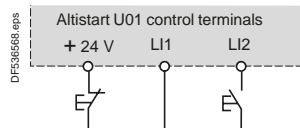

Wiring diagram for 3-wire control

■ Starting time

Controlling the starting time means that the time of the voltage ramp applied to the motor can be adjusted to obtain a gradual starting time, dependent on the motor load.

■ Voltage boost function via logic input

Activating the BOOST logic input enables the function for supplying a starting overtorque capable of overcoming any mechanical friction.

When the input is at state 1, the function is active (input connected to the + 24 V) and the starter applies a fixed voltage to the motor for a limited time before starting.

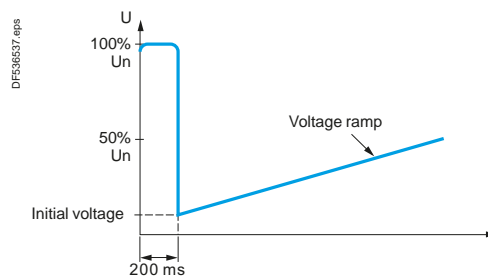

Application of a voltage boost equal to 100% of the nominal motor voltage

■ End of starting

□ application function for logic output LO1

ATSU 01N2●LT soft start/soft stop units are equipped with an open collector logic output LO, which indicates the end of starting when the motor has reached nominal speed.

Environmental characteristics

Type of starter		ATSU 01N2●●LT	
Conformity to standards		Altistart U01 electronic starters have been developed to conform to the strictest international standards and the recommendations relating to electrical industrial control devices (IEC, EN), in particular standard IEC/EN 60947-4-2.	
Electromagnetic compatibility EMC		CISPR 11 level B, IEC 60947-4-2, level B	
Conducted and radiated emissions		CISPR 11 level B, IEC 60947-4-2, level B	
Harmonics		IEC 1000-3-2, IEC 1000-3-4	
EMC immunity		EN 50082-2, EN 50082-1	
Electrostatic discharge		IEC 61000-4-2 level 3	
Immunity to radiated radio-electrical interference		IEC 61000-4-3 level 3	
Immunity to electrical transients		IEC 61000-4-4 level 4	
Voltage/current impulse		IEC 61000-4-5 level 3	
Conducted and radiated emissions		IEC 61000-4-6 level 3	
Immunity to conducted interference caused by radio-electrical fields		IEC 61000-4-11	
Damped oscillating waves		IEC 61000-4-12 level 3	
CE marking		The starters carry CE marking in accordance with the European low voltage directives IEC/EN 60947-4-2.	
Product certifications		UL, CSA, C-Tick and CCC	
Degree of protection		IP 20	
Degree of pollution		2 conforming to IEC/EN 60947-4-2	
Vibration resistance		1.5 mm peak to peak from 3 to 13 Hz, 1 gn from 13 to 150 Hz, conforming to IEC/EN 60068-2-6	
Shock resistance		15 gn for 11 ms conforming to IEC/EN 60068-2-27	
Relative humidity		5...95 % without condensation or dripping water conforming to IEC 60068-2-3	
Ambient temperature around the unit		Storage	°C -25...+70 conforming to IEC/EN 60947-4-2
		Operation	°C -10...+40 without derating, up to 50°C with current derating of 2 % per °C above 40°C
Maximum operating altitude		m	1000 without derating (above this, derate the current by 2.2 % per additional 100 m)
Operating position			
Maximum permanent angle in relation to the normal vertical mounting position			

Electrical characteristics

Type of starter		ATSU 01N2●●LT						
Category of use		Conforming to IEC 60947-4-2						
Rated operating voltage		3-phase ~ voltage						
		V	200 - 10 % to 480 + 10 %					
Frequency		Hz	50 - 5 % to 60 + 5 %					
Output voltage		Maximum 3-phase voltage equal to line supply voltage						
Control supply voltage		24 V ~, 100 mA ±10 %						
Rated operating current		A	6...32					
Adjustable starting time		s	1...10					
Adjustable deceleration time		s	1...10					
Starting torque		%	30... 80 % of DOL motor starting torque					
Type of starter	ATSU	01N206LT	01N209LT	01N212LT	01N222LT	01N232LT		
Control power supply consumption		24 V ~, 65 mA						
Power dissipated		24 V ~, 100 mA						
At full load at end of starting		W	1.5	1.5	1.5	2.5	2.5	
In transient state at 5 times the rated operating current		W	61.5	91.5	121.5	222.5	322.5	
Type of starter		ATSU 01N206LT to ATSU 01N222LT			ATSU 01N232LT			
Use								
Starting time		s	1	5	10	1	5	10
Maximum number of cycles per hour			100	20	10	50	10	5

Soft starters for asynchronous motors

Altistart U01 and TeSys U

Electrical characteristics (continued)		
Logic input power supply (electrically isolated between power and control) + 24 V, COM		24 V \pm 10 % Isolated Max. current 100 mA
Logic inputs LI1, LI2, BOOST Stop, run and boost on start-up functions		Logic inputs with impedance 27 k Ω ; 24 V power supply (U max 40 V) Max. current 8 mA State 0 if U < 5 V and I < 0.2 mA State 1 if U > 13 V and I > 0.5 mA
Logic output LO1 End of starting signal		Open collector logic output: External 24 V power supply (minimum 6 V, maximum 30 V) Max. current 200 mA
Relay output R1A R1C		Normally open (N/O) contact Minimum switching capacity: 10 mA for 6 V $\ddot{=}$ Maximum switching capacity on inductive load (cos ϕ = 0.5 and L/R = 20 ms): 2 A for 250 V \sim or 30 V $\ddot{=}$ (AC-15) Maximum operating voltage 440 V
LED signalling	Green LED	Starter powered up
	Yellow LED	Nominal voltage reached

Connections (maximum connection capacity and tightening torque)			
Power circuit		Connection to \varnothing 4 mm screw clamps	
Flexible wire without cable end	1 conductor	mm ²	1.5...10 8 AWG
	2 conductors	mm ²	1.5...6 10 AWG
Flexible wire with cable end	1 conductor	mm ²	1...6 10 AWG
	2 conductors	mm ²	1...6 10 AWG
Rigid wire	1 conductor	mm ²	1...10 8 AWG
	2 conductors	mm ²	1...6 10 AWG
Tightening torque		N.m	1.9...2.5
Control circuit		Screw connector	
Flexible wire without cable end	1 conductor	mm ²	0.5...2.5 14 AWG
	2 conductors	mm ²	0.5...1.5 16 AWG
Flexible wire with cable end	1 conductor	mm ²	0.5...1.5 16 AWG
	2 conductors	mm ²	0.5...1.5 16 AWG
Rigid wire	1 conductor	mm ²	0.5...2.5 14 AWG
	2 conductors	mm ²	0.5...1 17 AWG
Tightening torque		N.m	0.5

Torque characteristics (typical curves)

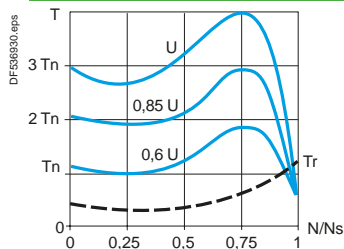

The diagram opposite shows the torque/speed characteristic of a cage motor in relation to the supply voltage.

The torque varies in line with the square of the voltage at a fixed frequency. The gradual increase in the voltage prevents the instantaneous current peak on power-up.

Soft starters for asynchronous motors

Altistart U01 and TeSys U



ATSU 01N222LT

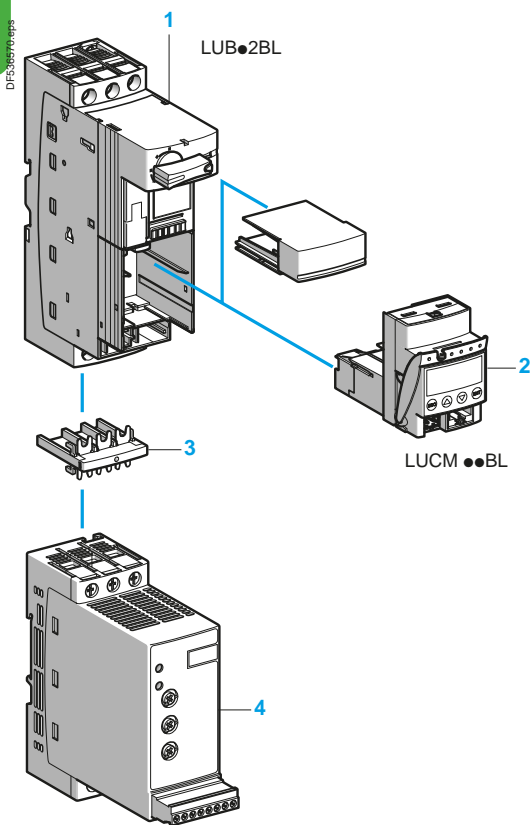

ATSU 01N2●●LT

Soft start/soft stop units for 0.75 to 15 kW motors (can be combined with the TeSys U starter)

Motor				Starter	
Motor power ⁽¹⁾				Nominal current	Reference
230 V		400 V	460 V		
kW	HP	kW	HP	A	
3-phase supply voltage: 200...480 V 50/60 Hz					
0.75	1	1.5	2	6	ATSU01N206LT
1.1	1.5	2.2	3		
		3			
1.5	2	–	5	9	ATSU01N209LT
–	–	4	–		
2.2	3	5.5	7.5	12	ATSU01N212LT
3	–	–	–		
4	5	7.5	10	22	ATSU01N222LT
5.5	7.5	11	15		
7.5	10	15	20	32	ATSU01N232LT

Accessories

Description	Used for starter	Reference
Power connector between ATSU 01N2●●LT and TeSys U	ATSU 01N2●●LT	VW3G4104

TeSys U starter and soft start unit combinations

Numerous possibilities for combinations and options are offered. Please consult the "TeSys U Starters-open version" specialist catalogue.

Motor power			Soft starter	TeSys U	
230 V	400 V	460 V		Power base	Control unit ⁽²⁾
kW/HP	kW	HP			
0.75/1	1.5	2	ATSU 01N206LT	LUB 12	LUC● 05BL
1.1/1.5	2.2/3	3	ATSU 01N206LT	LUB 12	LUC● 12BL
1.5/2	–	–	ATSU 01N209LT	LUB 12	LUC● 12BL
–	4	5	ATSU 01N209LT	LUB 12	LUC● 12BL
2.2/3	–	–	ATSU 01N212LT	LUB 12	LUC● 12BL
3/–	5.5	7.5	ATSU 01N212LT	LUB 32	LUC● 18BL
4/5	7.5	10	ATSU 01N222LT	LUB 32	LUC● 18BL
5.5/7.5	11	15	ATSU 01N222LT	LUB 32	LUC● 32BL
7.5/10	15	20	ATSU 01N232LT	LUB 32	LUC● 32BL

- Example of a starter-motor combination with:
- 1 non-reversing power base for DOL starting (LUB●2BL)
 - 2 control unit (LUCM●●BL)
 - 3 power connector (VW3 G4104)
 - 4 Altistart U01 soft start/soft stop unit (ATSU 01N2●●LT)

(1) Standard motor power ratings, HP power ratings indicated according to standard UL 508.
 (2) Depending on the configuration of the chosen TeSys U starter, replace the ● with A for standard, B for expandable, and M for multifunction.

Dimensions - TeSys U

Soft starters for asynchronous motors

Altistart U01 and TeSys U

TeSys U combination (non-reversing power base) and ATSU 01N206LT to ATSU 01N212LT
Mounting on \perp (35 mm) rail with VW3 G4104 connector

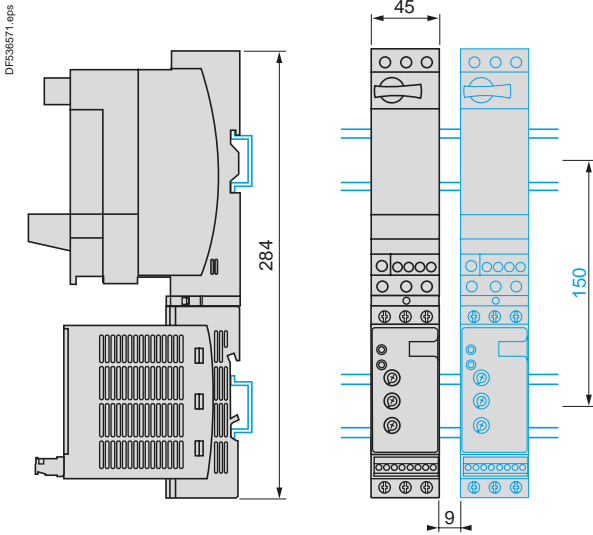

TeSys U combination (non-reversing or reversing power base) and ATSU 01N206LT to ATSU 01N212LT
Side by side mounting

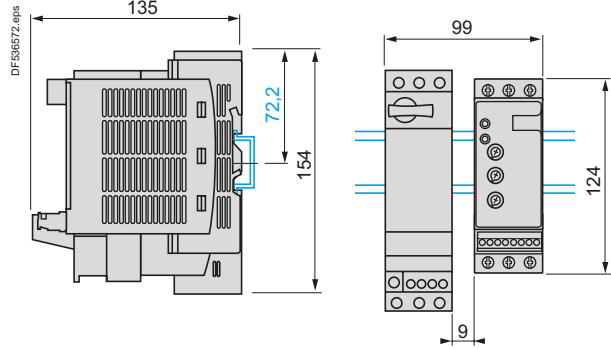

TeSys U combination (non-reversing power base) and ATSU 01N222LT to ATSU 01N232LT
Mounting on \perp (35 mm) rail with VW3 G4104 connector

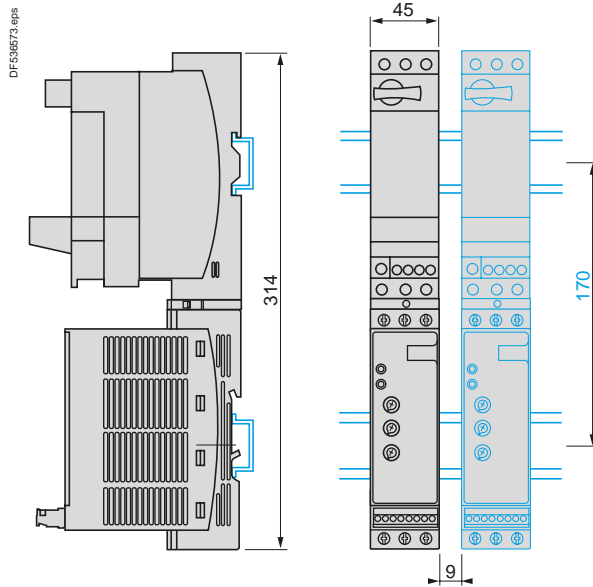

TeSys U combination (non-reversing or reversing power base) and ATSU 01N222LT to ATSU 01N232LT
Side by side mounting

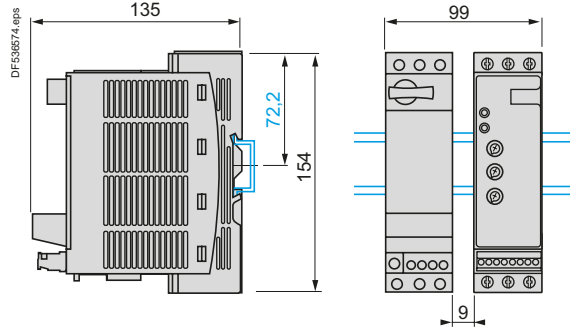

VW3 G4104 connector

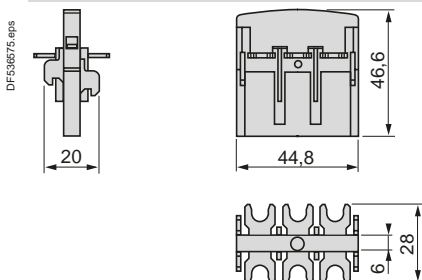

Schemes - TeSys U

Soft starters for asynchronous motors

Altistart U01 and TeSys U

For 0.75 to 15 kW motors

ATSU 01N2●●LT soft start/soft stop units

Power wiring

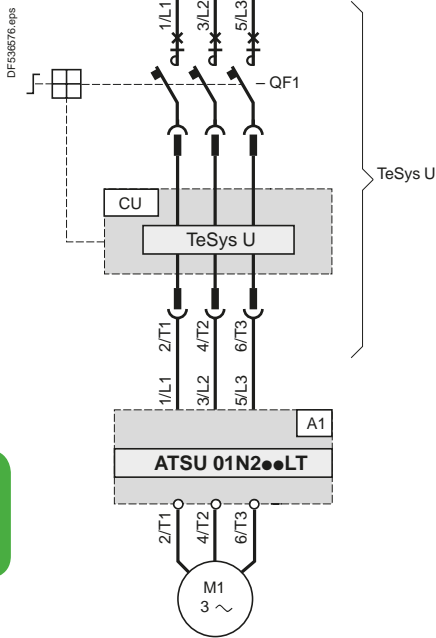

Power wiring with reversing unit

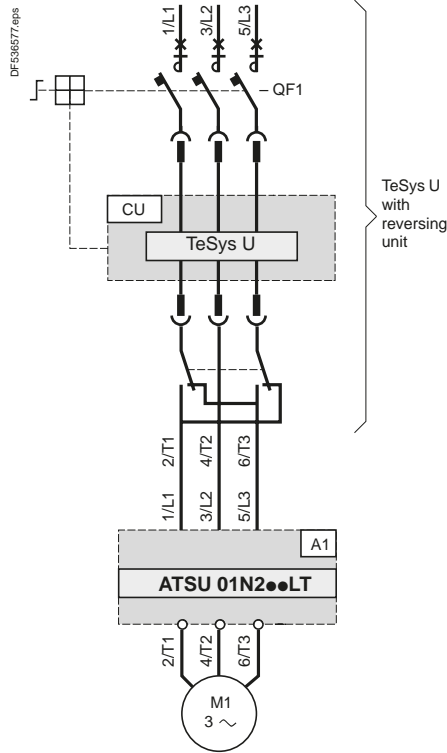

TeSys U

Compatible components

Code	Description
A1	Soft start/soft stop unit
QF1	TeSys U controller-starter
CU	TeSys U control unit

Soft starters for asynchronous motors

Altistart U01 and TeSys U

For 0.75 to 15 kW motors

ATSU 01N2●●LT soft start/soft stop units (continued)

Automatic 2-wire control

Without deceleration

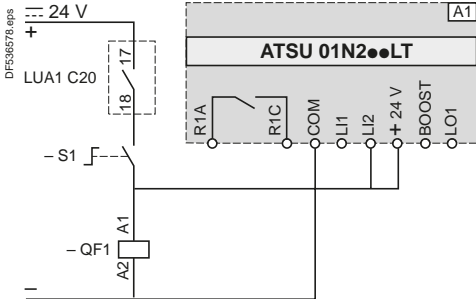

With and without deceleration

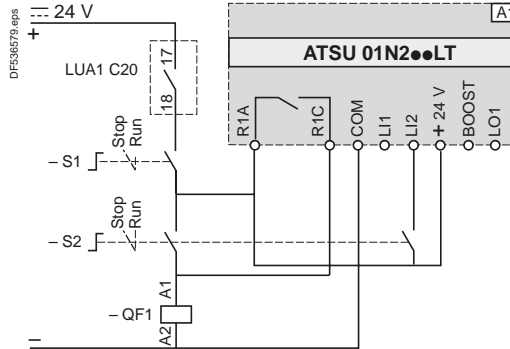

Functional diagrams

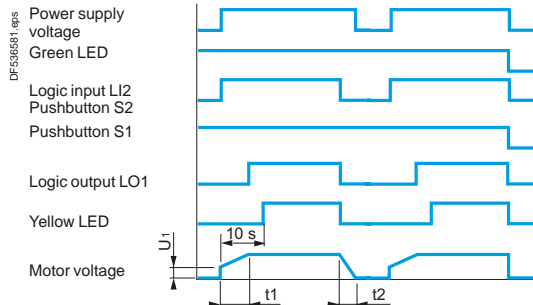
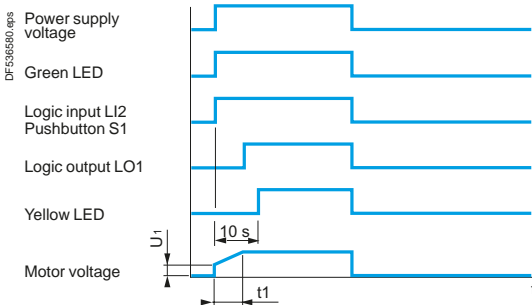

Automatic 3-wire control

Without deceleration

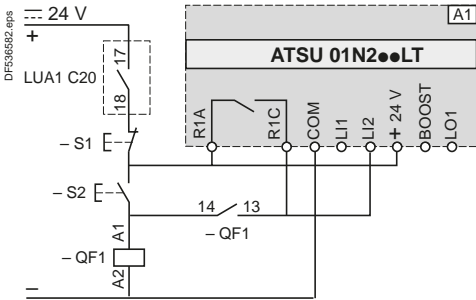

With deceleration

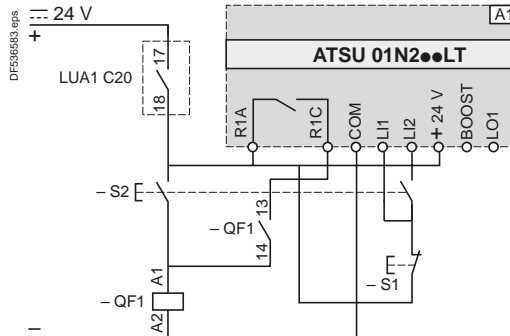

Functional diagrams

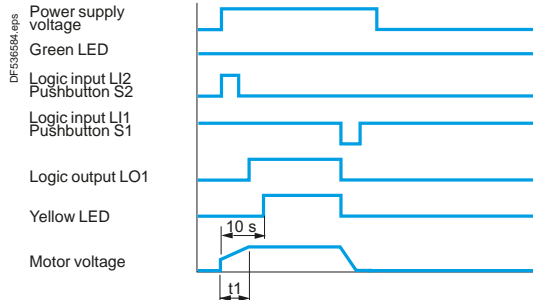
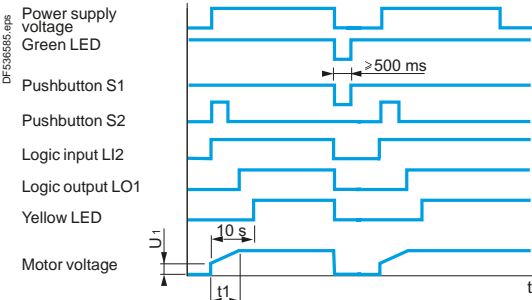

A1: Soft start/soft stop unit
 S1, S2: XB4 B or XB5 B pushbuttons
 QF1: TeSys U controller-starter
 t1: Acceleration time can be controlled by a potentiometer
 t2: Deceleration time can be controlled by a potentiometer
 U_s: Starting time can be controlled by a potentiometer

Soft starters for asynchronous motors

Altistart U01 and TeSys U

For 0.75 to 15 kW motors

ATSU 01N2●●LT soft start/soft stop units (continued)

Automatic 3-wire control, with reversing unit

Without deceleration

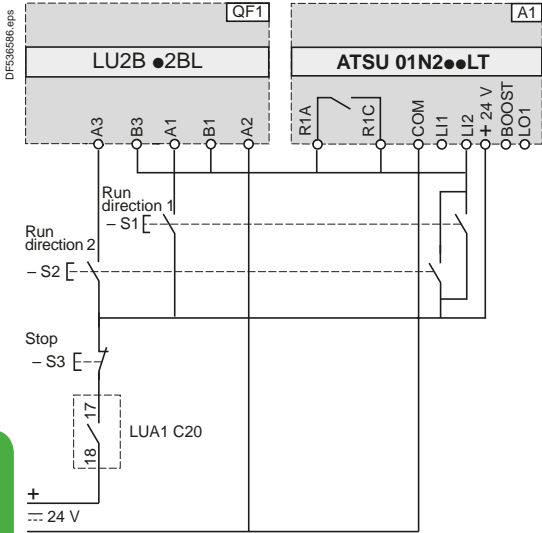

With deceleration

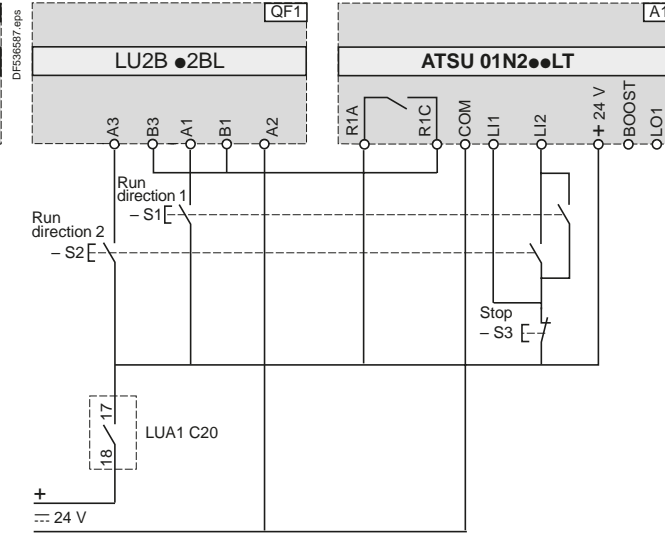

QF1: TeSys U controller-starter with reversing unit

A1: Soft start/soft stop unit

S1, S2, S3: XB4 B or XB5 B pushbuttons

S3: minimum depression time 500 ms

QF1: TeSys U controller-starter with reversing unit

A1: Soft start/soft stop unit

S1, S2, S3: XB4 B or XB5 B pushbuttons

Boost on starting and end of starting signal

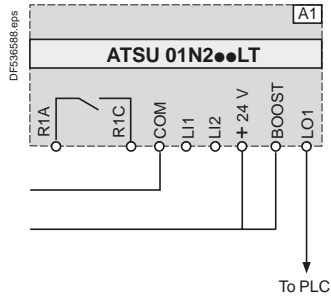

A1: Soft start/soft stop unit

Soft starters for asynchronous motors

Altistart U01 and TeSys U

For 0.75 to 15 kW motors

ATSU 01N2●●LT soft start/soft stop units (continued)

Automatic control with Modbus communication module, with and without deceleration

Without reversing unit

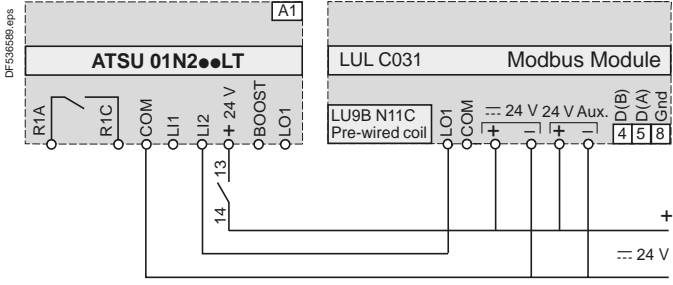

With reversing unit

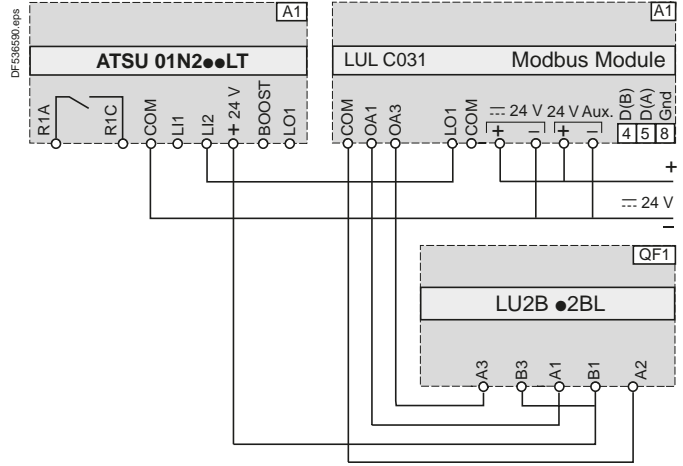

Function	Register	Bit	Value
Powering down TeSys U and ATSU			
-	704	0	0
Automatic control without deceleration			
Run	700	0	1
Stop	704	0	0
Automatic control with deceleration			
Run	700	0	1
Soft stop	700	0	0

Function	Register	Bit	Value
Powering up TeSys U and ATSU			
Forward	704	0	1
Reverse	704	1	1
Powering down TeSys U and ATSU			
Forward	704	0	0
Reverse	704	1	0
Automatic control without deceleration			
Run	700	0	1
Stop forward	704	0	0
Stop reverse	704	1	0
Automatic control with deceleration (forward or reverse)			
Run	700	0	1
Soft stop	700	0	0

A1: Soft start/soft stop unit

A1: Soft start/soft stop unit

QF1: TeSys U controller-starter with reversing unit

Automatic control with AS-Interface communication module, without deceleration

Without reversing unit

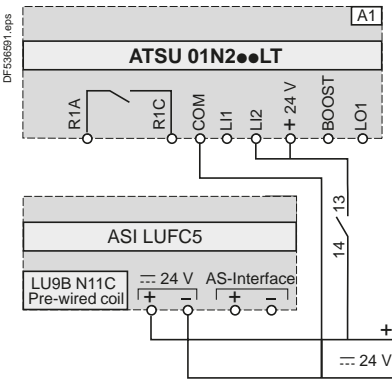

With reversing unit

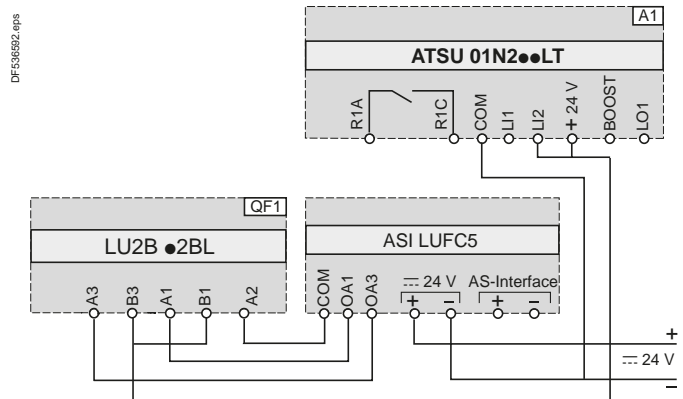

Function	Bit	Value
Power-up and automatic control without deceleration		
Run	D0	1
Stop	D0	0

Function	Bit	Value
Power-up and automatic control without deceleration		
Run forward	D0	1
Stop	D0	0
Run reverse	D1	1
Stop	D1	0

A1: Soft start/soft stop unit

A1: Soft start/soft stop unit

QF1: TeSys U controller-starter with reversing unit

Presentation, description, references - TeSys U

TeSys motor starters - open version

Magnetic control unit for the protection of variable speed controllers and soft start units

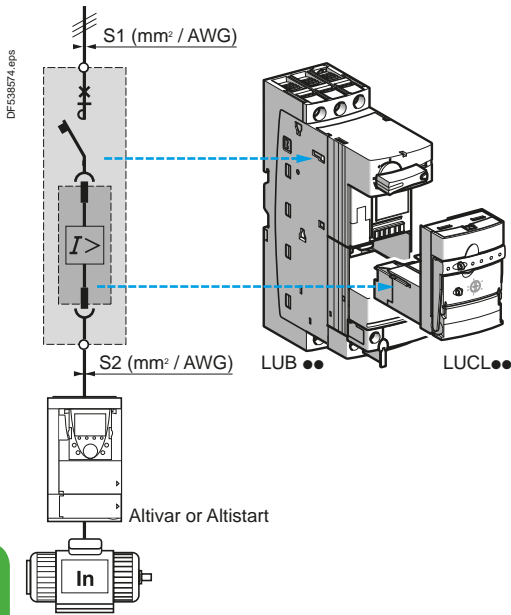

Presentation

When installed upstream of a variable speed controller or soft start unit, control unit LUCL●●, used in conjunction with an LUB 12 or LUB 32 power base, provides:

- isolation,
- short-circuit protection of the motor starter.
(variable speed controller-based or soft start unit-based motor starters).

Note: control unit LUCL, when used in conjunction with power base LUB 12 or LUB 32, conforms to standard IEC 60947-2.

Installation regulations

When the length of the cable between the TeSys U starter and the variable speed controller is more than 1.5 m, the c.s.a. of the cable between the variable speed controller and the TeSys U starter (S2) must be equal to the c.s.a. of the cable upstream of TeSys U (S1).

Description

- 1 Extraction and locking handle
- 2 Sealing of locking handle
- 3 Dial for magnetic adjustment of motor In
- 4 Locking of settings by sealing the transparent cover

References

Description	Line current of the variable speed controller or soft start unit	Reference ⁽¹⁾
A		
Magnetic control unit	0.15...0.6	LUCLX6●●
	0.35...1.4	LUCL1X●●
	1.25...5	LUCL05●●
	3...12	LUCL12●●
	4.5...18	LUCL18●●
	8...32	LUCL32●●

⁽¹⁾ Standard control circuit voltage:

Volts	24	48...72	110...240
≡	BL ^{(2) (3)}	—	—
~	B	—	—
≡ or ~	—	ES ⁽⁴⁾	FU ⁽⁵⁾

⁽²⁾ Voltage code to be used for a starter-controller with communication module.

⁽³⁾ d.c. voltage with maximum ripple of ±10 %.

⁽⁴⁾ ≡: 48...72 V, ~: 48 V.

⁽⁵⁾ ≡: 110...220 V, ~: 110...240 V.

TeSys U

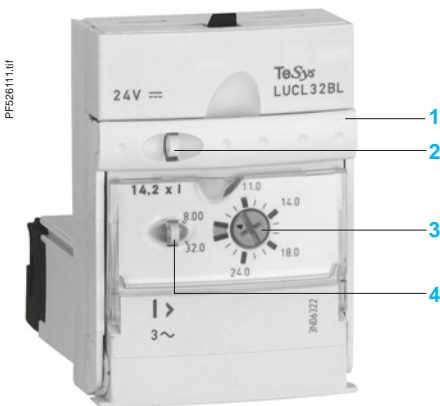

TeSys motor starters - open version

Magnetic control unit for the protection of variable speed controllers and soft start stop units

Control unit and associated power base selection						
Functions provided	Maximum motor power ratings 50/60 Hz			Power base reference	Control unit reference	Line current
	< 400/415 V	500 V	690 V			
	KW	KW	KW			
■ Short-circuit protection	0.09	–	–	LUB12 or LUB32	LUCLX6●●	0.15...0.6
■ Manual reset	0.25	–	–	LUB12 or LUB32	LUCL1X●●	0.35...1.4
	1.5	2.2	3	LUB12 or LUB32	LUCL05●●	1.25...5
	5.5	5.5	9	LUB12 or LUB32	LUCL12●●	3...12
	7.5	9	15	LUB32	LUCL18●●	4.5...18
	15	15	18.5	LUB32	LUCL32●●	8...32

Operating characteristics						
Control units	Standard		Advanced			Multifunction
	LUCA	LUCB	LUCC	LUCD	LUCL	LUCM
Thermal overload protection	Integrated function					
Over current protection	14.2 x the setting current					3 to 17 x the setting current
Short-circuit protection	13 x I _r max (max current setting)					
Protection against phase loss	Integrated function					
Protection against phase imbalance	Integrated function					
Earth fault protection (equipment protection only)	Integrated function					
Tripping class	10		10	20		5...30
Motor type	3-phase		Single-phase	3-phase	Single-phase and 3-phase	
Thermal overload test function	Integrated function					
Overtorque	Integrated function					
No-load running	Integrated function					
Long starting time	Integrated function					
Reset method	Manual	Integrated function				Parameters can be set
	Automatic or remote	With function module, or parameters can be set via the bus with a communication module (see page 24614/2).				Parameters can be set Parameters can be set via the bus with a communication module (see page 24614/2).

 Integrated function

 Function provided with accessory

Compatibility			
Compatibility of control unit LUC●● with	References	Functions	
The starter-controller	Yes	LUB 12/LUB 32	Starter-controller (magnetic protection)
The starter	No	LUS 12/LUS 32	Starter without either magnetic or thermal overload protection)
The controller	No	LUT M	Controller (without thermal overload protection)
Add-on contact blocks with fault signalling and auxiliary contacts	Yes	LUA 1C11 LUA 1C20 LUF N20 LUF N11 LUF N02	Add-on contact blocks with fault signalling (1 N/O + 1 N/C) Add-on contact blocks with fault signalling (2 N/O) Auxiliary contacts (2 N/O) Auxiliary contacts (1 N/O + 1 N/C) Auxiliary contacts (2 N/C)
Communication modules	Yes	ASILUF C5 and ASILUF C51 LUF C00 LUL C07 LUL C08 LUL C09 LUL C15 LUL C031 LUL C033	AS-Interface communication modules Parallel wiring module Profibus DP communication module (1 output/2 inputs) CANopen communication module (1 output/2 inputs) DeviceNet communication module (1 output/2 inputs) Advantys STB communication module (1 output/2 inputs) Modbus communication module (1 output) Modbus communication module (1 output/2 inputs)
Function modules	No	LUF W10 LUF DH11 LUF DA01 LUF DA10 LUF V2	Alarm function module Thermal overload signalling module with manual reset Thermal overload signalling module with automatic or remote reset (1 N/C) Thermal overload signalling module with automatic or remote reset (1 N/O) Motor load indication module

TeSys U

Characteristics of magnetic control unit LUCL			
Protection	Motor type		3-phase
	Conforming to standard		When used in conjunction with an LUB 12 or LUB 32 power base, magnetic control unit LUCL conforms to standard IEC 60947-2.
Short-circuit protection	Tripping threshold		14.2 x I _n (max. setting current)
	Tripping tolerance		±20 %
Environment			
Product certifications			CE
Conforming to standards			When used in conjunction an LUB power base, control unit LUCL conforms to standard 60947-2.
Rated insulation voltage (U _i)	Conforming to IEC/EN 60947-1, overvoltage category III, degree of pollution: 3	V	690
Rated impulse withstand voltage (U _{imp})	Conforming to IEC/EN 60947-2	kV	6
Safety separation of circuits SELV	Conforming to IEC/EN 60947-1 appendix N	V	Between the control or auxiliary circuit and the main circuit: 400 Between the control and auxiliary circuits: 40
Degree of protection (protection against direct finger contact)	Front panel outside connection zone		IP 40
	Front panel and wired terminals		IP 20
	Other faces		IP 20
Protective treatment	Conforming to IEC/EN 60068		"TH"
	Conforming to EN 60068-2-30	Cycles	12
	Conforming to IEC/EN 60068-2-11	h	48
Ambient air temperature around the device	Storage	°C	- 40...+ 85
	Operation	°C	Power bases and standard and advanced control units: - 25... + 70. (At temperatures above 60°C and up to 70°C, for I _e = 32 A, leave a minimum gap of 9 mm between products). Power bases and multifunction control units: - 25...+ 60. (At temperatures above 45 °C, leave a minimum gap of 9 mm between products. At temperatures above 55 °C up to 60 °C, leave a gap of 20 mm between products.)
Maximum operating altitude		m	2000
Operating positions	In relation to normal vertical mounting plane		
Flame resistance	Conforming to UL 94		V2
	Conforming to IEC/EN 60695-2-12	°C	960 (parts supporting live components) °C 650
Environmental restrictions			Cadmium and silicone-free, recyclable
Shock resistance 1/2 sine wave = 11 ms	Conforming to IEC/EN60068-2-27 ⁽¹⁾		Power poles open: 10 gn Power poles closed: 15 gn
Vibration resistance 5...300 Hz	Conforming to IEC/EN 60068-2-6 ⁽¹⁾		Power poles open: 2 gn Power poles closed: 4 gn ⁽²⁾
Resistance to electrostatic discharge	Conforming to IEC/EN 61000-4-2	kV	In open air: 8 - Level 3
		kV	On contact: 8 - Level 4
Immunity to radiated high-frequency disturbance	Conforming to IEC/EN 61000-4-3	V/m	10 - Level 3
Immunity to fast transient currents	Conforming to IEC/EN 61000-4-4	kV	All circuits except for serial link: 4 - Level 4
		kV	Serial link: 2 - Level 3
Immunity to dissipated shock waves	Conforming to IEC/EN 60947-2 U _c ~ 24...240 V, U _c ~ 48...220 V U _c = 24 V ~	kV	Common mode
			Serial mode
			2
			1
			Not applicable
Immunity to conducted high-frequency disturbance	Conforming to IEC/EN 61000-4-6	V	10

(1) Without modifying the contact states, in the most unfavourable direction.
(2) 2 gn with Advantys STB or CANopen communication modules.

TeSys motor starters - open version

TeSys U starter-controllers

Power bases and LUCL magnetic control unit

Power circuit connection characteristics					
Power base and control unit type		LUB 12 + LUCL		LUB 32 + LUCL	
Connection to Ø4 mm screw clamp terminals					
Flexible cable without cable end	1 conductor	mm ²	2.5...10		2.5...10
	2 conductors	mm ²	1.5...6		1.5...6
Flexible cable with cable end	1 conductor	mm ²	1...6		1...6
	2 conductors	mm ²	1...6		1...6
Flexible cable without cable end	1 conductor	mm ²	1...10		1...10
	2 conductors	mm ²	1...6		1...6
Screwdriver		Philips n° 2 or flat screwdriver: Ø6 mm			
Tightening torque		N.m	1.9...2.5		1.9...2.5
Control circuit connection characteristics					
Connection to Ø3 mm screw clamp terminals					
Flexible cable without cable end	1 conductor	mm ²	0.75...1.5		0.75...1.5
	2 conductors	mm ²	0.75...1.5		0.75...1.5
Flexible cable with cable end	1 conductor	mm ²	0.34...1.5		0.34...1.5
	2 conductors	mm ²	0.34...1.5		0.34...1.5
Flexible cable without cable end	1 conductor	mm ²	0.75...1.5		0.75...1.5
	2 conductors	mm ²	0.75...1.5		0.75...1.5
Screwdriver		Philips n° 2 or flat screwdriver: Ø5 mm			
Tightening torque		N.m	0.8...1.2		0.8...1.2
Control circuit characteristics					
Rated control circuit voltage	~ 50/60 Hz	V	24...240		24...240
	≡	V	24...220		24...220
Voltage limits	≡ 24 V ⁽¹⁾	V	20...27		20...27
	Operation				
	~ 24 V	V	20...26.5		20...26.5
	~ or ≡ 48...72 V	V	~ 38.5...72, ≡ 38.5...93		~ 38.5...72, ≡ 38.5...93
	~ 110...240 V	V	~ 88...264		~ 88...264
Drop-out	≡ 110...240 V	V	≡ 88...242		≡ 88...242
	~ 24 V	V	14.5		14.5
	~ 24 V	V	14.5		14.5
	~ or ≡ 48...72 V	V	29		29
	~ 110...240 V, ≡ 110...220 V	V	55		55
Typical consumption	≡ 24 V	mA	130		220
	I max while closing				
	~ 24 V	mA	140		220
	~ or ≡ 48...72 V	mA	280		280
	~ 110...240 V, ≡ 110...220 V	mA	280		280
I rms sealed	≡ 24 V	mA	60		80
	~ 24 V	mA	70		90
	~ or ≡ 48...72 V	mA	35		45
	~ 110...240 V, ≡ 110...220 V	mA	35		25
Heat dissipation		W	2		3
Operating time	Closing	ms	24 V: 70; 48 V: 60; ≥ 72 V: 50		24 V: 70; 48 V: 60; ≥ 72 V: 50
	Opening	ms	35		35
Resistance to micro-breaks		ms	3		3
Resistance to voltage dips		IEC/EN 61000-4-11	At least 70 % of Uc for 500 ms		
Mechanical durability		In millions of operating cycles	15		15
Maximum operating rate		In operating cycles per hour	3600		3600
Main pole characteristics					
Number of poles			3		3
Isolation conforming to IEC/EN 60947-1	Possible		Yes		Yes
	Padlocking		1 padlock with Ø6.9 mm shank		1 padlock with Ø6.9 mm shank
Rated thermal current		A	12		32
Rated operational current (Ue ≤ 440 V)	Conforming to IEC/EN 60947-2	Category AC-41	θ ≤ 70 °C: 12 A		θ ≤ 70 °C: 32 A
		Category AC-43	θ ≤ 70 °C: 12 A		θ ≤ 70 °C: 32 A
Rated operational voltage		V	690 ⁽³⁾		690 ⁽³⁾
Frequency limits		Of the operating current	Hz		40...60
Power dissipated in the power circuits	Operational current	A	3 6 9 12 18 25 32		
	Power dissipated in all three poles	W	0.1 0.3 0.6 1.1 2.4 4.6 7.5		
Rated breaking capacity on short-circuit		V	230 440 500 600		
		kA	50 50 10 4		
Total breaking time		ms	2 2 2		
Thermal limit		With Isc max on 440 V	kA ² s		90 120

(1) d.c. voltage with maximum ripple of ± 10 %.

(2) No consumption sealed.

(3) For 690 V, use phase barrier LU9SP0.

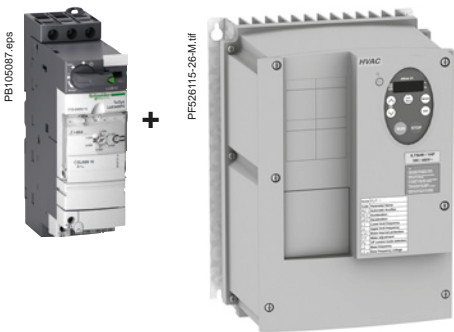
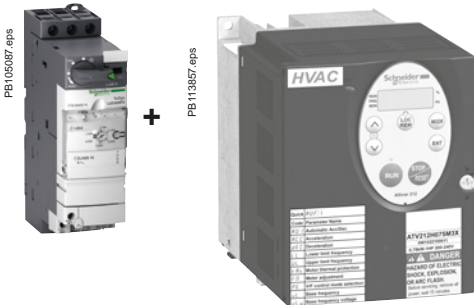
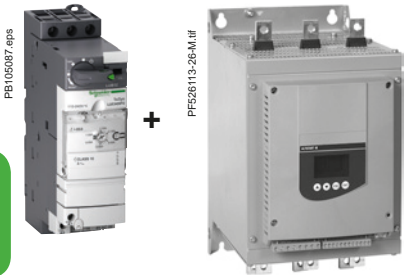

Coordination

The standard defines tests at different levels of current; the purpose of these tests is to place the equipment in extreme conditions.

The standard defines 2 types of coordination, according to the condition of the components after testing: type 1 and type 2.

Type 1 coordination requires that in a short-circuit condition, the contactor or starter must not present any danger to personnel or installations and must not be able to resume operation without repair or the replacement of parts.

The product combinations given below provide type 1 coordination

Soft start-soft stop unit/TeSys U starter controller combination with magnetic protection

TeSys U / Altistart 48: type 1 coordination

Power 400 V (kW)	TeSys U references (protection + power switching)	Soft start unit reference	
		Class 10	Class 20
5.5	LUB32 + LUCL32 or LUCL18	-	ATS48D17
7.5	LUB32 + LUCL32	ATS48D17	ATS48D22
11	LUB32 + LUCL32	ATS48D22	ATS48D32
15	LUB32 + LUCL32	ATS48D32	ATS48D38

Variable speed controller/TeSys U starter controller combination with magnetic protection

TeSys U / Altivar 21 UL Type 1/IP 20: type 1 coordination

Power 400 V (kW)	TeSys U references (protection + power switching)	Variable speed controller reference
0.75	LUB12 + LUCL05	ATV21H075N4 ATV21HU15N4
2.2	LUB12 + LUCL12	ATV21HU22N4
3	LUB12 + LUCL12	ATV21HU30N4
4	LUB12 + LUCL12	ATV21HU40N4
5.5	LUB32 + LUCL32 or LUCL18	ATV21HU55N4
7.5	LUB32 + LUCL32 or LUCL18	ATV21HU75N4
11	LUB32 + LUCL32	ATV21HD11N4
15	LUB32 + LUCL32	ATV21HD15N4

TeSys U / Altivar 21 IP 54: type 1 coordination

Power 400 V (kW)	TeSys U references (protection + power switching)	Variable speed controller reference
0.75	LUB12 + LUCL05	ATV21W075N4/N4C
1.5	LUB12 + LUCL12 or LUCL05	ATV21WU15N4/N4C
2.2	LUB12 + LUCL12	ATV21WU22N4/N4C
3	LUB12 + LUCL12	ATV21WU30N4/N4C
4	LUB12 + LUCL12	ATV21WU40N4/N4C
5.5	LUB32 + LUCL32 or LUCL18	ATV21WU55N4/N4C
7.5	LUB32 + LUCL32 or LUCL18	ATV21WU75N4/N4C
11	LUB32 + LUCL32	ATV21WD11N4/N4C
15	LUB32 + LUCL32	ATV21WD15N4/N4C

Combinations - TeSys U

TeSys motor starters - open version

TeSys U starter-controllers

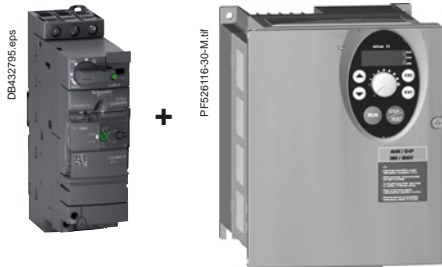

Variable speed controller/TeSys U starter controller combination with magnetic protection (continued)

TeSys U / Altivar 31: type 1 coordination

Power 400 V (kW)	TeSys U references (protection + power switching)	Variable speed controller reference
0.37	LUB12 + LUCL05	ATV31H037N4
0.55	LUB12 + LUCL05	ATV31H055N4
0.75	LUB12 + LUCL05	ATV31H075N4
1.1	LUB12 + LUCL12	ATV31HU11N4
1.5	LUB12 + LUCL12	ATV31HU15N4
2.2	LUB12 + LUCL12	ATV31HU22N4
3	LUB32 + LUCL18	ATV31HU30N4
4	LUB32 + LUCL18	ATV31HU40N4
5.5	LUB32 + LUCL32	ATV31HU55N4
7.5	LUB32 + LUCL32	ATV31HU75N4

TeSys U / Altivar 61: type 1 coordination

Power 400V (kW)	TeSys U references (protection + power switching)	Variable speed controller reference
0.75	LUB12 + LUCL05	ATV61H075N4
1.5	LUB12 + LUCL12	ATV61HU15N4
2.2	LUB12 + LUCL12	ATV61HU22N4
3	LUB32 + LUCL18	ATV61HU30N4
4	LUB32 + LUCL18	ATV61HU40N4
5.5	LUB32 + LUCL32	ATV61HU55N4
7.5	LUB32 + LUCL32	ATV61HU75N4

TeSys U / Altivar 71: type 1 coordination

Power 400V (kW)	TeSys U references (protection + power switching)	Variable speed controller reference
0.75	LUB12 + LUCL05	ATV71H075N4
1.5	LUB12 + LUCL12	ATV71HU15N4
2.2	LUB12 + LUCL12	ATV71HU22N4
3	LUB32 + LUCL18	ATV71HU30N4
4	LUB32 + LUCL18	ATV71HU40N4
5.5	LUB32 + LUCL32	ATV71HU55N4