



## DATA SHEET

# Specifications for probes and modules for classes 210 and 310 portables



## Pressure / Temperature module



### • Pressure

Part No.	Measuring units	Measuring range	Accuracy*	Resolution	Tolerated overpressure	Compatible devices
MPR 500	Pa, mmH <sub>2</sub> O, In WG, mbar, hPa, mmHg, daPa, kPa	From 0 to ±500 Pa From 2 to 28 m/s**	From -100 to +100 Pa: ±0.2% of reading ±0.8 Pa Beyond: ±0.2% de la lecture ±1.5 Pa	From -100 to +100 Pa: 0.1 Pa Beyond: 1 Pa	250 mbar	MP 210 AMI 310
MPR 2500	Pa, mmH <sub>2</sub> O, In WG, mbar, hPa, mmHg, daPa, kPa	From 0 to ±2500 Pa From 2 to 60 m/s**	±0.2% of reading ±2 Pa	From -100 to +100 Pa: 0.1 Pa Beyond: 1 Pa	500 mbar	MP 210 AMI 310
MPR 10000	Pa, mmH <sub>2</sub> O, In WG, mbar, hPa, mmHg, daPa, kPa	From 0 to ±10000 Pa From 4 to 100 m/s**	±0.2% of reading ±10 Pa	1 Pa	1200 mbar	MP 210 AMI 310
MPR 500 M	mmH <sub>2</sub> O, In WG, mbar, hPa, mmHg, daPa, kPa, PSI	From 0 to ±500 mbar From 9 to 100 m/s**	±0.2% of reading ±0.5 mbar	0.1 mbar	2 bar	MP 210 AMI 310
MPR 2000 M	bar, In WG, mbar, hPa, mmHg, kPa, PSI	From 0 to ±2000 mbar From 18 to 100 m/s**	±0.2% of reading ±2 mbar	1 mbar	6 bar	MP 210 AMI 310

Response time  $t_{95}$ : 0.5 s.

### • Thermocouple temperature

Measuring units	Measuring range	Accuracy*	Resolution	Compatible devices
°C, °F	K: From -200 to +1300°C J: From -100 to +750°C T: From -200 to +400°C S: From 0 to 1760°C N: From -200 to 1300°C	K, J, T, N: From -200 to 0°C: ±0.4°C ±0.3% of reading. From 0 to 1300°C: ±0.4°C S: ±0.6°C	From -100 to +100 Pa: 0.1 Pa Beyond: 1 Pa	MP 210 AMI 310

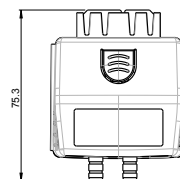
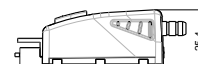
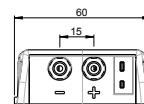

## Pitot tube



Part No.	Measuring units	Measuring range	Accuracy*	Resolution	Compatible devices
See specific data sheet	Air velocity: m/s, fpm, km/h, mph	From 3 to 5 m/s From 5.1 to 85 m/s	±0.3 m/s ±0.5% of reading ±0.2 m/s	0.1 m/s	MP 210 AMI 310
See specific data sheet	Airflow: m <sup>3</sup> /h, cfm, l/s, m <sup>3</sup> /s	From 0 to 99999 m <sup>3</sup> /h	±0.2% of reading ±1% FS	1 m <sup>3</sup> /h	MP 210 AMI 310

\*All the accuracies indicated in this technical datasheet were stated in laboratory conditions, and can be guaranteed for measurements carried out in the same conditions, or carried out with calibration compensation.  
\*\*According to the airflow device coefficient connected to the device.

## Debimo blades

Part No.	Measuring units	Measuring range	Accuracy*	Resolution	Compatible devices
See specific data sheet	Air velocity: m/s, fpm, km/h, mph	From 3 to 20 m/s From 21 to 40 m/s	$\pm 0.3$ m/s $\pm 1\%$ of reading $\pm 0.1$ m/s	0.1 m/s	MP 210 AMI 310
See specific data sheet	Air flow: m <sup>3</sup> /h, cfm, l/s, m <sup>3</sup> /s	From 0 to 99999 m <sup>3</sup> /h	$\pm 0.2\%$ of reading $\pm 1\%$ FS	1 m <sup>3</sup> /h	MP 210 AMI 310



## Thermocouple temperature

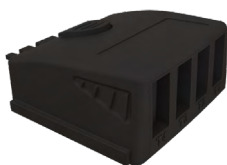

Part No.	Measuring units	Measuring range	Accuracy*	Resolution	Compatible devices
M4TC	$^{\circ}\text{C}$ , $^{\circ}\text{F}$	K: From -200 to +1300 $^{\circ}\text{C}$ J: From -100 to +750 $^{\circ}\text{C}$ T: From -200 to +400 $^{\circ}\text{C}$ S: From 0 to +1760 $^{\circ}\text{C}$ N: From -200 to +1300 $^{\circ}\text{C}$	K, J, T, N: From -200 to 0 $^{\circ}\text{C}$ : $\pm 0.4^{\circ}\text{C} \pm 0.3\%$ of reading From 0 to 1300 $^{\circ}\text{C}$ : $\pm 0.4^{\circ}\text{C}$ S: $\pm 0.6^{\circ}\text{C}$	0.1 $^{\circ}\text{C}$	HQ 210 MP 210 VT 210 TM 210 AMI 310

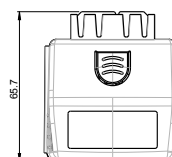
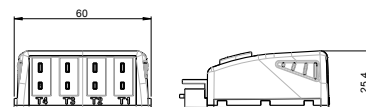

## U coefficient module

Part No.	Measuring units	Measuring range	Accuracy*	Resolution	Compatible devices
MCU	$^{\circ}\text{C}$ , $^{\circ}\text{F}$ W/m <sup>2</sup>	T Thermocouple: From -20 to +80 $^{\circ}\text{C}$	$\pm 0.3^{\circ}\text{C}$	0.1 $^{\circ}\text{C}$	TM 210 AMI 310

Please refer to "U coefficient module explanatory note" for more details about the U coefficient module (document available upon request)

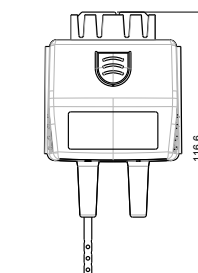
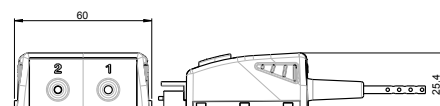

## Climatic conditions module



Part No.	Measuring units	Measuring range	Accuracy*	Resolution	Compatible devices
MCC	Temperature: $^{\circ}\text{C}$ , $^{\circ}\text{F}$	From 0 to +50 $^{\circ}\text{C}$	$\pm 0.4\%$ of reading $\pm 0.3^{\circ}\text{C}$	0.1 $^{\circ}\text{C}$	HQ 210 VT 210 AMI 310
MCC	Atmospheric pressure: hPa	From 800 to 1100 hPa	$\pm 3$ hPa	1 hPa	HQ 210 VT 210 AMI 310
MCC	Hygrometry: %RH	From 0 to 100%RH	Accuracy (Repeatability, linearity, Hysteresis): $\pm 1.8\%$ RH (from 15 $^{\circ}\text{C}$ to 25 $^{\circ}\text{C}$ and from 5 to 95% RH) Factory calibration uncertainty: $\pm 0.88\%$ RH Temperature dependence: $\pm 0.04 \times (T-20)$ % RH (if T < 15 $^{\circ}\text{C}$ or T > 25 $^{\circ}\text{C}$ )	0.1%RH	HQ 210 VT 210 AMI 310

Response time  $t_{93}$ : hygrometry 50 s / temperature 25 s / atmospheric pressure 0.5 s.

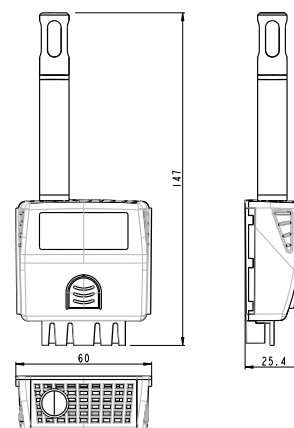

\*All the accuracies indicated in this technical datasheet were stated in laboratory conditions, and can be guaranteed for measurements carried out in the same conditions, or carried out with calibration compensation.  
\*\*Specific adjustment and calibration in option

## Hot-wire probe / Telescopic hot-wire probe / Telescopic hot-wire gooseneck probe

Part No.	Measuring units	Measuring range	Accuracy*	Resolution	Compatible devices
SFC 300 SFC 900 SFC 900 GN	Air velocity: m/s, fpm, km/h, mph	From 0.15 to 1 m/s	±2% of reading ±0.03 m/s Specific adjustment and calibration in option	0.01 m/s	MP 210 VT 210 AMI 310
SFC 300 SFC 900 SFC 900 GN	Air velocity: m/s, fpm, km/h, mph	From 0.15 to 3 m/s From 3.1 to 30 m/s	±3% of reading ±0.03 m/s ±3% of reading ±0.1 m/s	0.01 m/s 0.1 m/s	MP 210 VT 210 AMI 310
SFC 300 SFC 900 SFC 900 GN	Air flow: m³/h, cfm, l/s, m³/s	From 0 to 99999 m³/h	±3% of reading or ±0.03* sheath surface (cm²)	1 m³/h	MP 210 VT 210 AMI 310
SFC 300 SFC 900 SFC 900 GN	Temperature: °C, °F	From -20 to +80°C	±0.3% of reading ±0.25°C	0.1°C	MP 210 VT 210 AMI 310

Response time  $t_{0.95}$ : air velocity and airflow 0.6 s / temperature 5 s

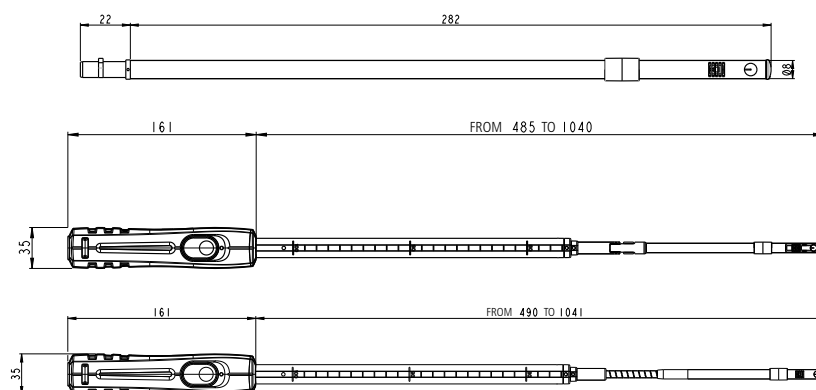

## Hot wire Air velocity measurement probe for Laboratory hood

Part No.	Measuring units	Measuring range	Accuracy*	Resolution	Compatible devices
SFC 300 S**	Air velocity: m/s, fpm, km/h, mph	From 0.15 to 3 m/s From 3.1 to 5 m/s	±5% of reading ±0.02 m/s	0.01 m/s 0.1 m/s	MP 210 VT 210 AMI 310
SFC 300 S**	Air flow: m³/h, cfm, l/s, m³/s	From 0 to 99999 m³/h	±5% of reading or ±0.02*sheath surface (cm²)	1 m³/h	MP 210 VT 210 AMI 310
SFC 300 S**	Temperature: °C, °F	From 0 to +50°C	±0.3% of reading ±0.25°C	0.1°C	MP 210 VT 210 AMI 310

Response time  $t_{0.95}$ : air velocity and airflow 0.6 s / temperature 5 s

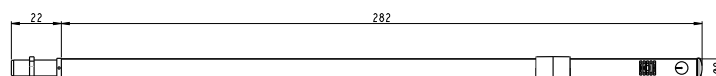

## Hot wire Omnidirectional Telescopic probe

Part No.	Measuring units	Measuring range	Accuracy*	Resolution	Compatible devices
SOM 900	Air velocity: m/s, fpm, km/h	From 0.00 to 5.00 m/s	±3% of reading ±0.05 m/s	0.01 m/s	HQ 210 AMI 310
SOM 900	Relative humidity: %RH	From 0 to 100%RH	Accuracy (Repeatability, linearity, Hysteresis): ±1.8% RH (from 15°C to 25°C and from 5 to 95% RH) Factory calibration uncertainty: ±0.88% RH Temperature dependence: ±0.04 x (T-20) % RH (if T<15°C or T>25°C)	0.1%RH	HQ 210 AMI 310
SOM 900	Temperature: °C, °F	From -20 to +80°C	±0.3% of reading ±0.25°C	0.1°C	HQ 210 AMI 310

Response time  $t_{0.95}$ : air velocity and airflow 0.6 s / temperature 5 s

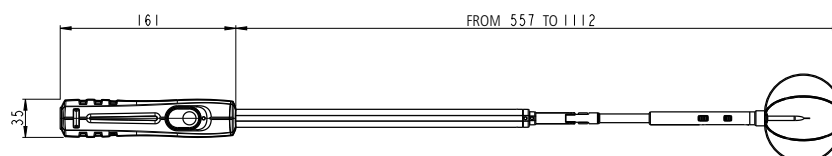

\*All the accuracies indicated in this technical datasheet were stated in laboratory conditions, and can be guaranteed for measurements carried out in the same conditions, or carried out with calibration compensation.  
\*\*Meets the EN 14175-3 standard.

## Ø14 mm Vane probe / Ø14 mm Telescopic Vane probe

Part No.	Measuring units	Measuring range	Accuracy*	Resolution	Compatible devices
SH 14 / SHT 14	Air velocity: m/s, fpm, km/h, mph	From 0 to 3 m/s From 3.1 to 25 m/s	From 0.8 to 3 m/s: $\pm 3\%$ of reading $\pm 0.1$ m/s From 3.1 to 25 m/s: $\pm 1\%$ of reading $\pm 0.3$ m/s	0.1 m/s	MP 210 VT 210 AMI 310
SH 14 / SHT 14	Air flow: m <sup>3</sup> /h, cfm, l/s, m <sup>3</sup> /s	From 0 to 99999 m <sup>3</sup> /h	$\pm 3\%$ of reading or $\pm 0.03$ *sheath surface (cm <sup>2</sup> )	1 m <sup>3</sup> /h	MP 210 VT 210 AMI 310
SH 14 / SHT 14	Temperature: °C, °F	From -20 to +80°C	$\pm 0.4\%$ of reading $\pm 0.3$ °C	0.1°C	MP 210 VT 210 AMI 310

Response time  $t_{93}$ : air velocity and airflow 0.6 s / temperature 5 s.

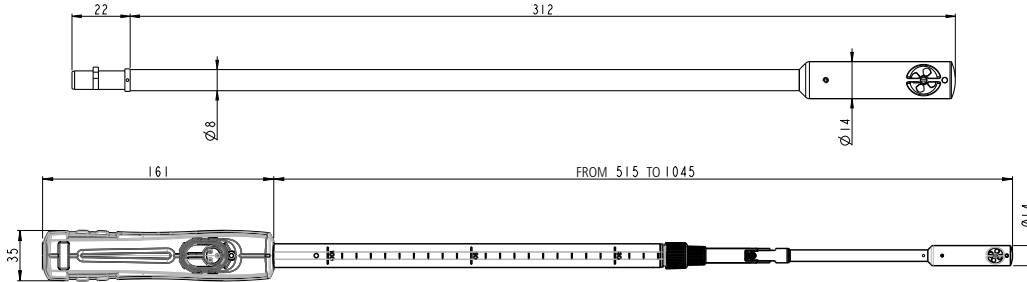

## Ø70 mm Vane probe / Ø70 mm Telescopic Vane probe

Part No.	Measuring units	Measuring range	Accuracy*	Resolution	Compatible devices
SH 70 SHT 70 SHF 70**	Air velocity: m/s, fpm, km/h, mph	From -5 to 3 m/s From 3.1 to 35 m/s	From 0.4 to 3 m/s: $\pm 3\%$ of reading $\pm 0.1$ m/s From 3.1 to 35 m/s: $\pm 1\%$ of reading $\pm 0.3$ m/s	0.1 m/s	MP 210 VT 210 AMI 310
SH 70 SHT 70 SHF 70**	Air flow: m <sup>3</sup> /h, cfm, l/s, m <sup>3</sup> /s	From 0 to 99999 m <sup>3</sup> /h	$\pm 3\%$ of reading or $\pm 0.03$ *sheath surface (cm <sup>2</sup> )	1 m <sup>3</sup> /h	MP 210 VT 210 AMI 310
SH 70 SHT 70 SHF 70**	Temperature: °C, °F	From -20 to +80°C	$\pm 0.4\%$ of reading $\pm 0.3$ °C	0.1°C	MP 210 VT 210 AMI 310

Response time  $t_{93}$ : air velocity, airflow and temperature 0.8 s.

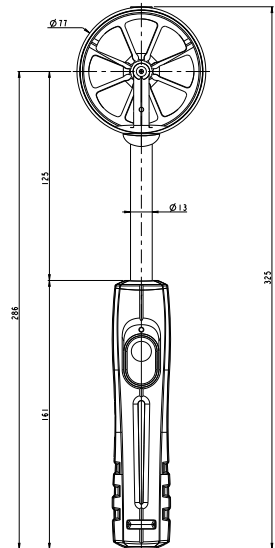
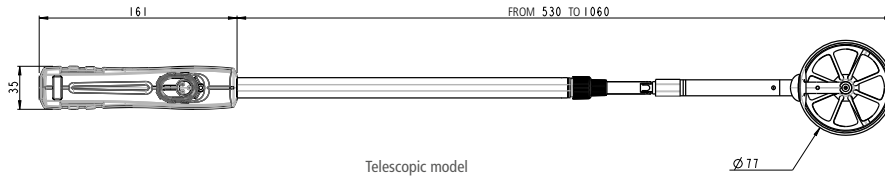

## Ø100 mm Vane probe / Ø100 mm Telescopic Vane probe

Part No.	Measuring units	Measuring range	Accuracy*	Resolution	Compatible devices
SH 100 SHT 100 SHF 100**	Air velocity: m/s, fpm, km/h, mph	From -5 to 3 m/s From 3.1 to 35 m/s	From 0.3 to 3 m/s: $\pm 3\%$ of reading $\pm 0.1$ m/s From 3.1 to 35 m/s: $\pm 1\%$ of reading $\pm 0.3$ m/s	0.01 m/s 0.1 m/s	MP 210 VT 210 AMI 310
SH 100 SHT 100 SHF 100**	Air flow: m <sup>3</sup> /h, cfm, l/s, m <sup>3</sup> /s	From 0 to 99999 m <sup>3</sup> /h	$\pm 3\%$ of reading or $\pm 0.03$ *sheath surface (cm <sup>2</sup> )	1 m <sup>3</sup> /h	MP 210 VT 210 AMI 310
SH 100 SHT 100 SHF 100**	Temperature: °C, °F	From -20 to +80°C	$\pm 0.4\%$ of reading $\pm 0.3$ °C	0.1°C	MP 210 VT 210 AMI 310

Response time  $t_{93}$ : air velocity, airflow and temperature 1 s.

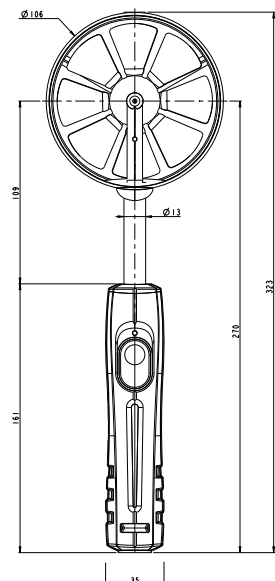
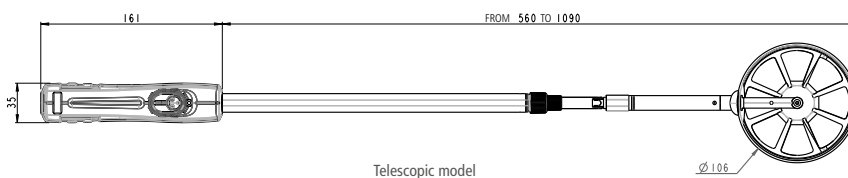

\*Radiofrequency model : maximum range between the probe and the device of 10m in free field without obstruction.

\*\*All the accuracies indicated in this technical datasheet were stated in laboratory conditions, and can be guaranteed for measurements carried out in the same conditions, or carried out with calibration compensation.

## Hot wire Multifunction probe

Part No.	Measuring units	Measuring range	Accuracy*	Resolution	Compatible devices
SMT 900	Air velocity: m/s, fpm, km/h, mph	From 0.15 to 3 m/s From 3.1 to 30 m/s	$\pm 3\%$ of reading $\pm 0.03$ m/s $\pm 3\%$ of reading $\pm 0.1$ m/s	0.01 m/s 0.1 m/s	VT 210 AMI 310
SMT 900	Air flow: m <sup>3</sup> /h, cfm, l/s, m <sup>3</sup> /s	From 0 to 99999 m <sup>3</sup> /h	$\pm 3\%$ of reading or $\pm 0.03$ * sheath surface (cm <sup>2</sup> )	1 m <sup>3</sup> /h	VT 210 AMI 310
SMT 900	Relative humidity: % RH	From 0 to 100% RH	Accuracy (Repeatability, linearity, Hysteresis) : $\pm 1.8\%$ RH (from 15°C to 25°C and from 5 to 95% RH) Factory calibration uncertainty : $\pm 0.88\%$ RH Temperature dependence : $\pm 0.04 \times (T-20)$ % RH (if T<15°C or T>25°C)	0.1% RH	VT 210 AMI 310
SMT 900	Temperature: °C, °F	From -20 to +80°C	$\pm 0.3\%$ de la lecture $\pm 0.25$ °C	0.1 °C	VT 210 AMI 310

Response time  $t_{93}$ : air velocity and airflow 0.6 s / temperature 5 s

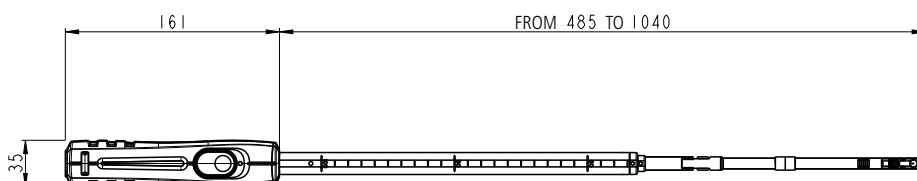

## Hygrometry probe

Part No.	Measuring units	Measuring range	Accuracy*	Resolution	Compatible devices
SHR 110 SHRF 1101	Relative humidity: % RH	From 0 to 100% RH	Accuracy (Repeatability, linearity, Hysteresis): $\pm 1.5\%$ RH (from 15°C to 25°C and from 3 to 98% RH) Factory calibration uncertainty: $\pm 0.88\%$ RH Temperature dependence: $\pm 0.04 \times (T-20)$ % RH (if T<15°C or T>25°C)	0.1% RH	HQ 210 VT 210 AMI 310
SHR 110 SHRF 1101	Absolute humidity: g/m <sup>3</sup>	From 0 to 600 g/m <sup>3</sup>	-	0.1 g/m <sup>3</sup>	HQ 210 VT 210 AMI 310
SHR 110 SHRF 1101	Enthalpy: kJ/kg	From 0 to 10000 kJ/kg	-	0.1 kJ/kg	HQ 210 VT 210 AMI 310
SHR 110 SHRF 1101	Combination ratio: g/kg	From 0 to 10000 g/kg	-	0.1 g/kg	HQ 210 VT 210 AMI 310
SHR 110 SHRF 1101	Wet temperature: °C, °F	From -50 to +100°C	-	0.1°C	HQ 210 VT 210 AMI 310
SHR 110 SHRF 1101	Dew point: °C <sub>td</sub> , °F <sub>td</sub>	From -50 to +100°C <sub>td</sub>	-	0.1°C <sub>td</sub>	HQ 210 VT 210 AMI 310
SHR 110 SHRF 1101	Temperature: °C, °F	From -20 to +80°C	-	0.1°C	HQ 210 VT 210 AMI 310

Response time  $T_{93}$ : relative humidity <10 s / temperature 7 s.

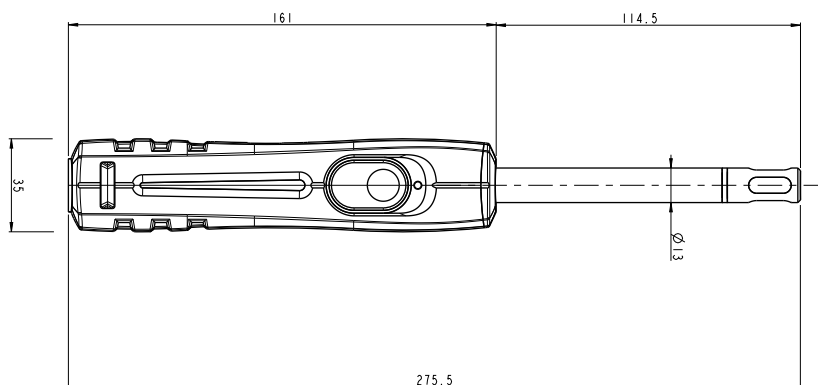

\*Radiofrequency model : maximum range between the probe and the device of 10m in free field without obstruction.

\*\*All the accuracies indicated in this technical datasheet were stated in laboratory conditions, and can be guaranteed for measurements carried out in the same conditions, or carried out with calibration compensation.

## High temperature Hygrometry probe

Part No.	Measuring units	Measuring range	Accuracy*	Resolution	Compatible devices
SHR 300 SHRF 300**	Relative humidity: %RH	From 0 to 100% RH	Accuracy (Repeatability, linearity, Hysteresis): $\pm 1.5\%$ RH (from 15°C to 25°C and from 3 to 98% RH) Factory calibration uncertainty: $\pm 0.88\%$ RH Temperature dependence: $\pm 0.04 \times (T-20)$ % RH (if $T < 15^\circ\text{C}$ or $T > 25^\circ\text{C}$ )	0.1% RH	HQ 210 VT 210 AMI 310
SHR 300 SHRF 300**	Absolute humidity: g/m <sup>3</sup>	From 0 to 600 g/m <sup>3</sup>	-	0.1 g/m <sup>3</sup>	HQ 210 VT 210 AMI 310
SHR 300 SHRF 300**	Enthalpy: kJ/kg	From 0 to 10000 kJ/kg	-	0.1 kJ/kg	HQ 210 VT 210 AMI 310
SHR 300 SHRF 300**	Combination ratio: g/kg	From 0 to 10000 g/kg	-	0.1 g/kg	HQ 210 VT 210 AMI 310
SHR 300 SHRF 300**	Wet temperature: °C, °F	From -50 to +100°C	-	0.1°C	HQ 210 VT 210 AMI 310
SHR 300 SHRF 300**	Dew point: °C <sub>td</sub> , °F <sub>td</sub>	From -50 to +100°C <sub>td</sub>	$\pm 0.6\%$ of reading $\pm 0.5^\circ\text{C}_{td}$	0.1°C <sub>td</sub>	HQ 210 VT 210 AMI 310
SHR 300 SHRF 300**	Temperature: °C, °F	From -40 to +180°C	$\pm 0.3\%$ of reading $\pm 0.25^\circ\text{C}$	0.1°C	HQ 210 VT 210 AMI 310

Response time  $T_{63}$ : relative humidity <10 s / temperature 7 s.

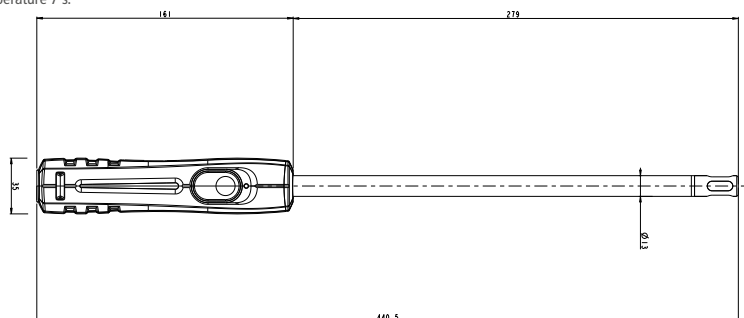

## CO / Temperature probe

Part No.	Measuring units	Measuring range	Accuracy*	Resolution	Compatible devices
SCO 110	Temperature: °C, °F CO: ppm	From -20 to +80°C From 0 to 500 ppm	$\pm 0.3\%$ of reading $\pm 0.25^\circ\text{C}$ From 0 to 50 ppm: $\pm 2$ ppm From 51 to 200 ppm: $\pm 3$ ppm From 201 to 500 ppm: $\pm 1.5\%$ of reading	0.1°C 0.1 ppm	HQ 210 MP 210 AMI 310

Response time  $T_{63}$ : 10 s.

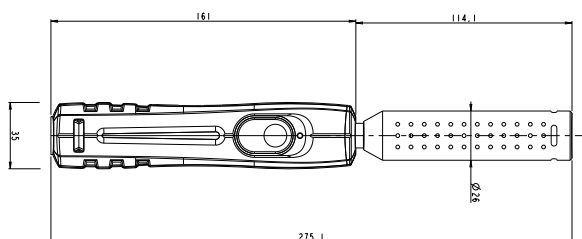

## CO<sub>2</sub> / Temperature probe

Part No.	Measuring units	Measuring range	Accuracy*	Resolution	Compatible devices
SCO 112	Temperature: °C, °F CO <sub>2</sub> : ppm	From -20 to +80°C From 0 to 5000 ppm	$\pm 0.3\%$ of reading $\pm 0.25^\circ\text{C}$ $\pm 3\%$ de la lecture $\pm 50$ ppm	0.1°C 1 ppm	HQ 210 AMI 310

Response time  $T_{63}$ : 30 s.

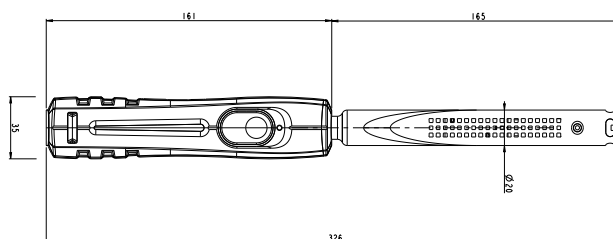

\*All the accuracies indicated in this technical datasheet were stated in laboratory conditions, and can be guaranteed for measurements carried out in the same conditions, or carried out with calibration compensation.

\*\*Radiofrequency model: maximum range between the probe and the device of 10m in free field without obstruction.

## CO<sub>2</sub> / Temperature / Hygrometry probe

Part No.	Measuring units	Measuring range	Accuracy*	Resolution	Compatible devices
SCOH 112	Temperature: °C, °F CO <sub>2</sub> : ppm Hygrometry: % RH	From -20 to +80°C From 0 to 5000 ppm From 0 to 100% RH	±0.3% of reading ±0.25°C ±3% of reading ±50ppm Accuracy (Repeatability, linearity, Hysteresis): ±1.8% RH (from 15°C to 25°C and from 5 to 95% RH) Factory calibration uncertainty: ±0.88% RH Temperature dependence: ±0.04 x (T-20) % RH (if T<15°C or T>25°C)	0.1°C 1 ppm 0.1% RH	HQ 210 AMI 310

Response time  $t_{95}$ : 30 s.

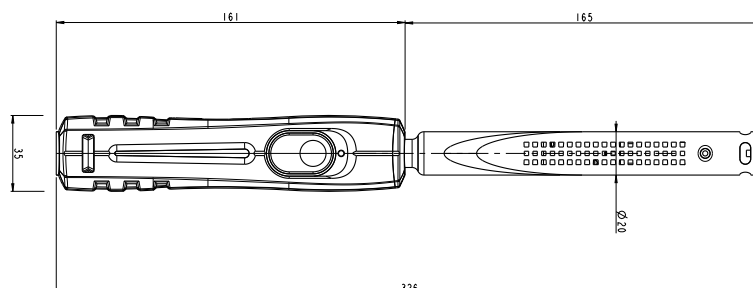

## Gas leak probe

Part No.	Measuring units	Measuring range	Accuracy*	Resolution	Compatible devices
SFG 300	ppm % LEL % VOL	From 0 to 10 000 ppm (GPL: 0-1800) From 0 to 20% LEL From 0 to 1% VOL	±20% of full scale	1 ppm 0.01% LEL 0.001% VOL	MP 210 AMI 310

Response time  $t_{95}$ : 10 s.

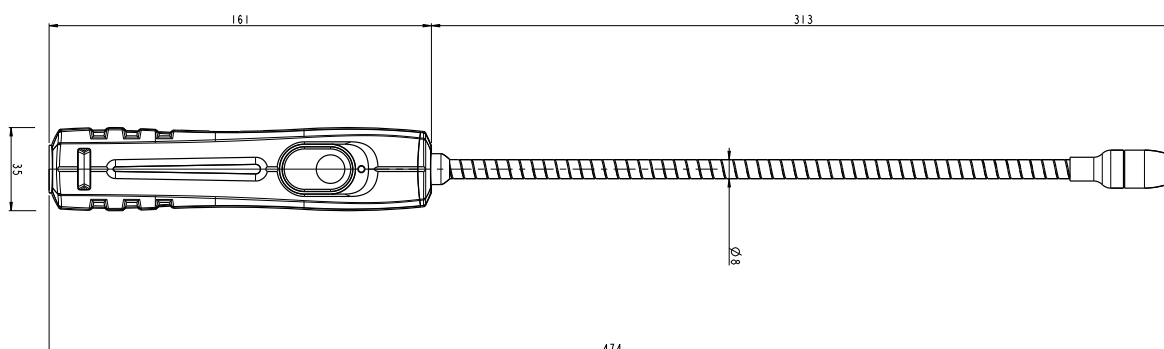

## Optical tachometry probe / Tachometry contact probe

Part No.	Probe	Measuring units	Measuring range	Accuracy*	Resolution	Compatible devices
STA	Optical	tr/min, rpm	From 60 to 10 000 tr/min From 10 001 to 60 000 tr/min	±0.3% of reading ±1 tr/min ±30 tr/min	1 tr/min	MP 210 VT 210 AMI 310

STA	Contact	tr/min, rpm	From 30 to 3000 tr/min	±1% of reading ±1 tr/min	1 tr/min	MP 210 VT 210 AMI 310
-----	---------	-------------	------------------------	--------------------------	----------	-----------------------------

Response time  $t_{95}$ : 2 s.

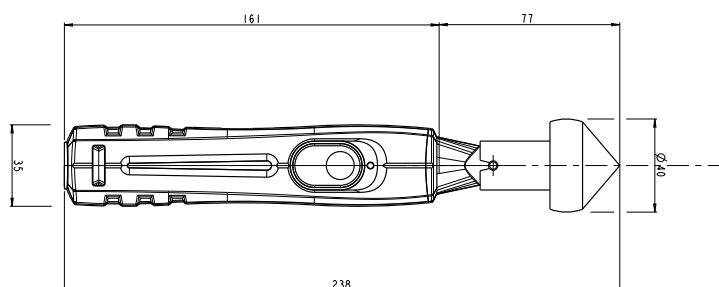

\*All the accuracies indicated in this technical datasheet were stated in laboratory conditions, and can be guaranteed for measurements carried out in the same conditions, or carried out with calibration compensation.

## Light probe

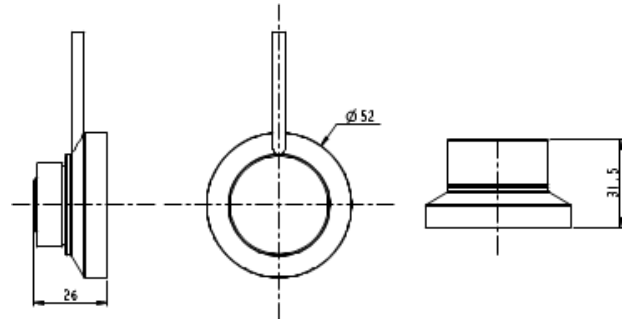

Part No.	Measuring units	Measuring range	Accuracy*	Resolution	Spectral range (f1)**	Directional sensitivity (f2)**	Linearity (f3)**	Appareil compatible
SLU	lux, klux, fc	From 0 to 150 000 lux From 0 to 13935 fc	±1% of reading or ±2 lux	From 0 to 999.9 lux: 0.1 lux From 1000 to 9999 lux: 1 lux From 10.00 to 99.99 klux: 0.01 klux From 100.0 to 150.0 klux: 0.1 klux	Compliant with the standard photopic curve V (λ) NF C 42-710 C class	<2%	<1%	HQ 210 AMI 310

Response time  $t_{0.95}$ : <1 s.

## Cable

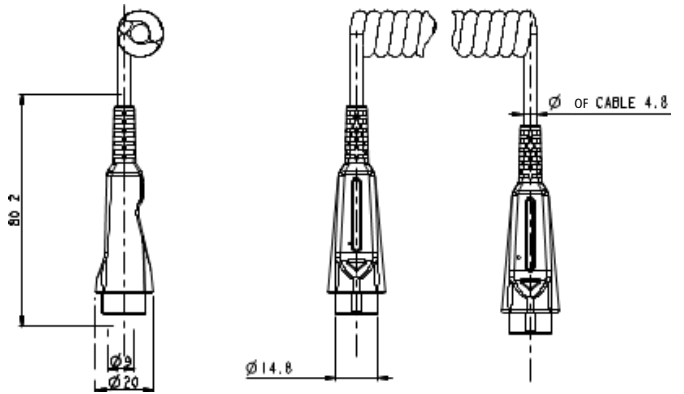

Part No.	Description
CSM	Min-DIN cable / min-DIN for probe 45 cm coil length 2 m useful length

## Adjustable rod

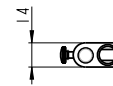

The adjustable rod is used with telescopic vane probes, telescopic hotwire probes and multifunction probes to perform air velocity, airflow or temperature measurements.

For instance, it allows to perform measurements in several points, keeping the same distance from the air vent outlet.

Référence	Description
PRST	Adjustable rod from 10 to 303 mm



Example of application

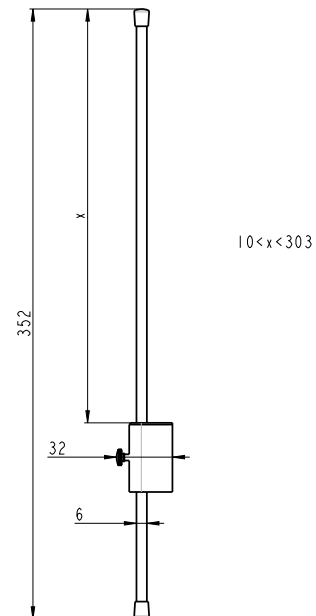

\*All the accuracies indicated in this technical datasheet were stated in laboratory conditions, and can be guaranteed for measurements carried out in the same conditions, or carried out with calibration compensation  
\*\* The f2 and f3 coefficients are defined according to the French NF C 42-710 standard.

 All dimensions specified on this document are indicated in millimetres.  
All handles are made in ABS with a -40 to +85°C operating temperature.

