

Safety Door Switch with Solenoid Interlock

SG-B1 SERIES

Ultra-slim

Safety Door Switch

SG-A1 SERIES



SG-B1 SERIES / SG-A1 SERIES

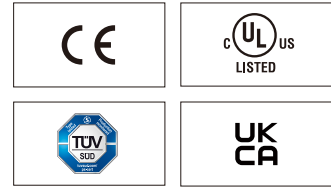

Ultra-slim safety door switch

Introducing a safety door switch with solenoid interlock that is among the world's **thinnest class***! With 5 built-in contacts

*Based on research conducted by our company as of May 2025.

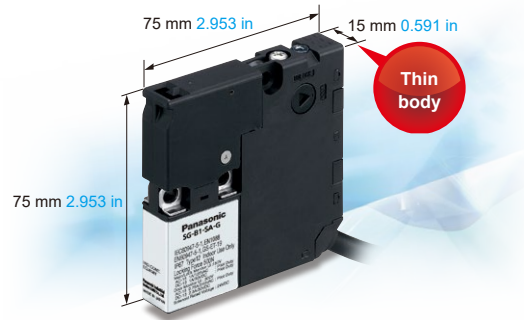

Manual lock release can be operated from three directions.



Space saving design with angled connection cable

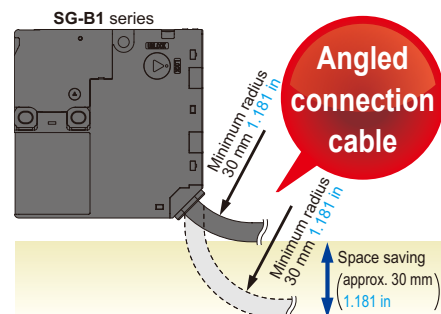

Can be installed on any door.

Sliding doors

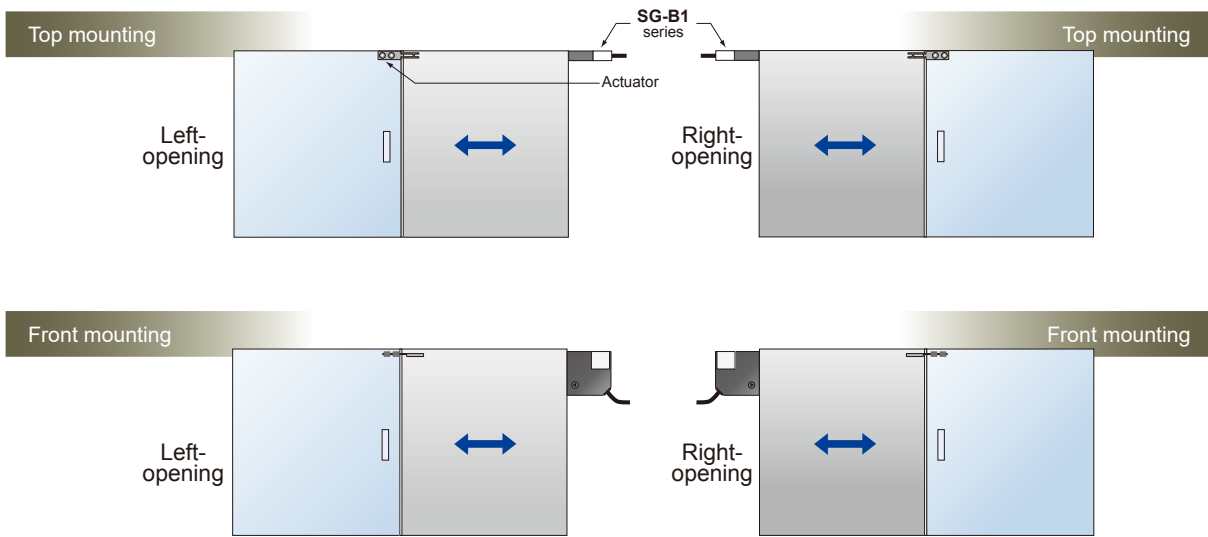

Hinged doors

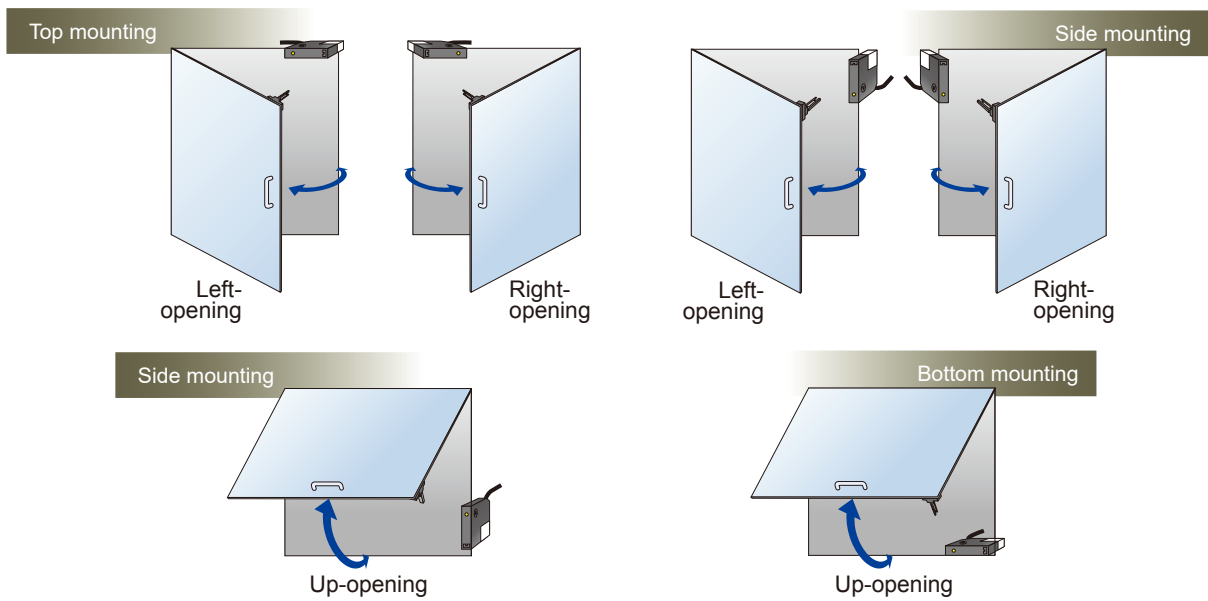

SG-B1 series

- Choose between two types of locks:
 - Spring lock
 - Magnet lock
- Easy-to-see LED operation indicator

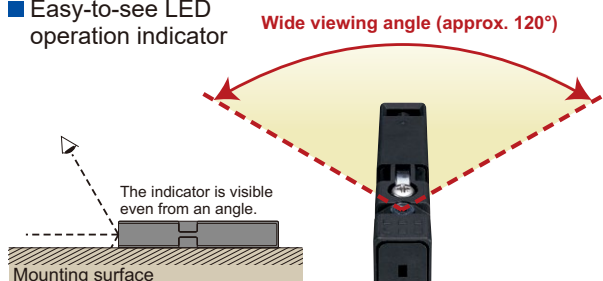

SG-A1 series

- Features three built-in contacts yet is among world's smallest designs.
- Choose from two actuator entry slot orientations.



All models come with cables pre-installed.

The **SG-B1** series and **SG-A1** series ship with bundled cables already connected internally. Since there is no need to provide cables separately, and because they are already connected internally, the number of wiring man-hours is cut in half.

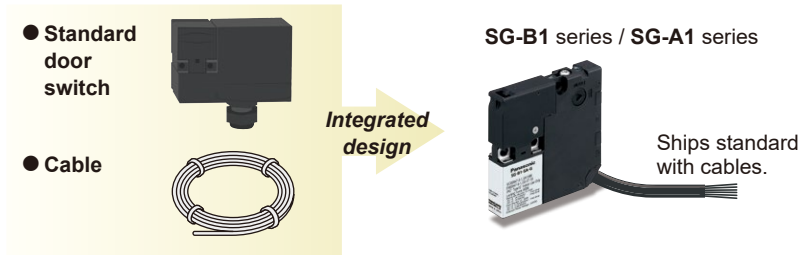

Energy-saving design

The **SG-B1** series features an energy-saving design requiring current consumption of just 110 mA at 24 V DC (100 mA for the solenoid and 10 mA for the indicator), even though it also incorporates a solenoid interlock.



Low power consumption of 110 mA

ORDER GUIDE

Safety door switch with solenoid interlock

Actuators are not included with door switches and must be purchased separately.

Type	Interlock force	Main contacts	Door monitor contacts	Lock monitor contacts	Cable length	Model No.
Spring lock type	500 N or more	1NC + 1NC	2NC	1NC	1 m 3.281 ft	SG-B1-SA-G1
					5 m 16.404 ft	SG-B1-SA-G5
				1NO	1 m 3.281 ft	SG-B1-SB-G1
					5 m 16.404 ft	SG-B1-SB-G5
Magnet lock type				1NC	1 m 3.281 ft	SG-B1-MA-G1
						5 m 16.404 ft
				1NO	1 m 3.281 ft	SG-B1-MB-G1
					5 m 16.404 ft	SG-B1-MB-G5

Safety door switch

Actuators are not included with door switches and must be purchased separately.

Door monitor contacts	Cable length	Model No.
2NC	1 m 3.281 ft	SG-A1-02-1
	5 m 16.404 ft	SG-A1-02-5
2NC + 1NO	1 m 3.281 ft	SG-A1-12-1
	5 m 16.404 ft	SG-A1-12-5
3NC	1 m 3.281 ft	SG-A1-03-1
	5 m 16.404 ft	SG-A1-03-5

Actuators

Actuators are not included with door switches and must be purchased separately.

Type	Model No.
Straight actuator	SG-K11
Right-angle actuator	SG-K12 (Note 1)
Right-angle actuator (with plate)	SG-K12A
Horizontal / vertical angle adjustable actuators (Note 2)	SG-K13
	SG-K14

• **SG-K11**



• **SG-K12**



• **SG-K12A**



• **SG-K13**



• **SG-K14**



Notes: 1) The right-angle **SG-K12** actuator's tensile strength is 100 N. Using the device with a load in excess of this value may cause it to fall off the door. If you anticipate that the tensile load during use will exceed 100 N, use the right-angle (with plate) **SG-K12A**.

2) Choose a model after verifying the required direction of operation based on the relationship between the door and safety switch.

CONTACT CONFIGURATION / OPERATING PATTERNS

Safety door switch with solenoid interlock

■ : Closed □ : Open

Safety switch status		Status 1	Status 2	Status 3	Status 4	Unlocking using manual unlocking key
		• Door closed • Machine ready to operate • Solenoid de-energized	• Door closed • Machine cannot be operated • Solenoid energized	• Door open • Machine cannot be operated • Solenoid energized	• Door open • Machine cannot be operated • Solenoid de-energized	• Door closed • Machine cannot be operated • Solenoid de-energized
Door status						
Door		• Closed (locked)	• Closed (unlocked)	• Open	• Open	• Closed (unlocked)
Model No. and contact configuration	Spring lock type SG-B1-SA-□ Magnet lock type SG-B1-MA-□	Main circuit 11-42				
	Door monitor circuit (door closed) 21-22					
	Door monitor circuit (door closed) 31-32					
	Lock monitor circuit (locked) 51-52					
	Diagram: Door monitor (At actuator entry), Lock monitor (When solenoid off), Main circuit: ⊕11, 12, 41, 42; Monitor circuit: ⊕21, 22, 51, 52; Monitor circuit: ⊕31, 32					
	Spring lock type SG-B1-SB-□ Magnet lock type SG-B1-MB-□	Main circuit 11-42				
	Door monitor circuit (door closed) 21-22					
	Door monitor circuit (door closed) 31-32					
	Lock monitor circuit (unlocked) 53-54					
	Diagram: Main circuit: ⊕11, 12, 41, 42; Monitor circuit: ⊕21, 22, 53, 54; Monitor circuit: ⊕31, 32					
Spring lock type Solenoid power A1-A2 (same for all models)	• OFF (de-energized)	• ON (energized)	• ON (energized)	• OFF (de-energized)	• OFF (de-energized)	
Magnet lock type Solenoid power A1-A2 (same for all models)	• ON (energized)	• OFF (de-energized)	• OFF (de-energized)	• ON (energized) (Note 2)	• OFF (de-energized) to ON (re-energized) (Note 1) (Note 2)	

Main circuit: Connected to the machine drive control circuit, sending the interlock signals of the protective door.
 Monitor circuit: Sends the monitoring signals of open / closed and lock / unlocked statuses of the protective door.
 Notes: 1) Do not attempt manual unlocking while the solenoid is energized.
 2) Do not energize the solenoid for a long period of time while the door is open or while the door is unlocked manually.

• **Operation characteristics** ■ : Contact ON (closed) □ : Contact OFF (opened) (reference)

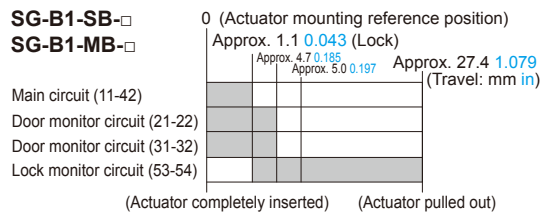
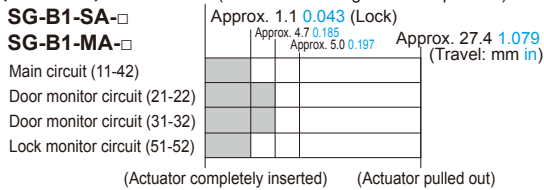



• The operation characteristics show the contact status when the actuator enters an entry slot of a safety switch.
 • The operation characteristics shown in the chart above are of the **SG-K11 / SG-K12 / SG-K13** and **SG-K14** actuators. For the **SG-K12A** actuator, subtract 0.6 mm **0.024 in.**

Safety door switch

Model No.	Contact configuration	Operation characteristics
SG-A1-02-□	2NC 	0.8 0.031 (Actuator mounting reference position) Approx. 5.5 0.217 Approx. 5.8 0.228 Approx. 28.2 1.110 (Travel: mm in) ■ : Contact ON (closed) □ : Contact OFF (opened)
SG-A1-12-□	2NC + 1NO 	
SG-A1-03-□	3NC 	

SPECIFICATIONS

Designation		Safety door switch with solenoid interlock					
Item	Series	SG-B1 series					
Applicable standards		EN 60947-5-1: 2017, GS-ET-19: 2019					
Standards for use		IEC 60204-1 / EN 60204-1, ISO 14119, EN ISO 14119, IEC 60947-5-1, UL 508, CSA C22.2 No.14					
Applicable regulations		CE Marking [Machinery Directive (2006/42/EC), RoHS Directive], UKCA Marking [Supply of Machinery (Safety) Regulations (2008 No.1597), RoHS Regulations]					
Operating condition	Ambient temperature	-25 to +50 °C -13 to +122 °F (No dew condensation or icing allowed) Storage: -40 to +80 °C -40 to +176 °F					
	Ambient humidity	45 to 85 % RH					
	Pollution degree	3 (Inside 2)					
	Altitude	2,000 m 6,561.68 ft max.					
Rated insulation voltage (Ui)		300 V (Door monitor circuit) 150 V (Main, Lock monitor circuit) 30 V (Between ground and LED, solenoid circuit)					
Impulse withstand voltage (Uimp)		2.5 kV (Door monitor circuit) 1.5 kV (Main, Lock monitor circuit) 0.5 kV (Between ground and LED, solenoid circuit)					
Thermal current (Ith)		Ambient temperature: -25 to +35 °C -13 to +95 °F 2.5 A (up to 2 circuits) 1.0 A (3 or more circuits)		Ambient temperature 35 to +50 °C 95 to +122 °F 1.0 A (1 circuit) 0.5 A (2 or more circuits)			
Rated operational voltage (Ue) / Rated operational current (Ie)		Ie					
				30 V	125 V	250 V	
		Main circuit, lock monitor circuit	AC	Resistive load (AC-12)	-	2 A	-
				Inductive load (AC-15)	-	1 A	-
			DC	Resistive load (DC-12)	2 A	0.4 A	-
				Inductive load (DC-13)	1 A	0.22 A	-
		Door monitor circuit	AC	Resistive load (AC-12)	-	2.5 A	1.5 A
				Inductive load (AC-15)	-	1.5 A	0.75 A
DC	Resistive load (DC-12)		2.5 A	1.1 A	0.55 A		
	Inductive load (DC-13)		2.3 A	0.55 A	0.27 A		
Electric shock protection class		Class II (IEC 61140) (Note 1),  (double insulated)					
Operating frequency		900 operations/hour					
Actuator operating speed		0.05 to 1.0 m/sec.					
B10d		2,000,000 (ISO 13849-1 Annex C Table C.1)					
Mechanical durability		1,000,000 operations min. (GS-ET-19)					
Electrical durability		100,000 operations min. (900 operations/hour, AC-12 125 V 2A, DC-12 125 V 0.4 A) 1,000,000 operations min. (900 operations/hour, 24 V AC/DC 0.1 A resistive load)					
Interlock force		500 N min. (GS-ET-19) (Note 2)					
Direct opening travel		8 mm 0.315 in min.					
Direct opening force		60 N min.					
Contact resistance		300 mΩ max. (initial value, 1 m 3.281 ft cable) 700 mΩ max. (initial value, 5 m 16.404 ft cable)					
Protection		IP67 (IEC 60529)					
Shock resistance		Malfunction: 100 m/s ² , Destruction: 1,000 m/s ²					
Vibration resistance		Malfunction: 10 to 55 Hz, half amplitude 0.35 mm 0.014 in Destruction: 30 Hz, half amplitude 1.5 mm 0.059 in					
Short-circuit protective device		Use 250 V / 10 A fast acting type fuse					
Material		Enclosure: PA66					
Cable		UL style 2464, No.22 AWG 12-core					
Solenoid / Indicator	Rated operating voltage	DC 24 V 100% duty cycle					
	Rated current	110 mA (solenoid 100 mA, LED 10 mA : initial value)					
	Turn on voltage	Rated voltage × 85 % max. (at 20 °C 68 °F)					
	Turn off voltage	Rated voltage × 10 % min. (at 20 °C 68 °F)					
	Indicator	Green LED					
Weight		SG-B1-□-G1 : Approx. 220 g, SG-B1-□-G5 : Approx. 600 g					

Designation		Safety door switch				
Item	Series	SG-A1 series				
Applicable standards		EN 60947-5-1: 2017, GS-ET-15: 2019				
Standards for use		IEC 60204-1 / EN 60204-1, ISO 14119, EN ISO 14119, IEC 60947-5-1, UL 508, CSA C22.2 No.14				
Applicable regulations		CE Marking [Machinery Directive (2006/42/EC), RoHS Directive], UKCA Marking [Supply of Machinery (Safety) Regulations (2008 No.1597), RoHS Regulations]				
Operating condition	Ambient temperature	-25 to +70 °C -13 to +158 °F (No dew condensation or icing allowed) Storage: -40 to +80 °C -40 to +176 °F				
	Ambient humidity	45 to 85 % RH				
	Pollution degree	3 (Inside 2)				
	Altitude	2,000 m 6,561.68 ft max.				
Impulse withstand voltage (Uimp)		4 kV				
Rated insulation voltage (Ui)		300 V				
Thermal current (Ith)		2.5 A				
Rated operational voltage (Ue) / Rated operational current (Ie)				30 V	125 V	250 V
		AC	Resistive load (AC-12)	-	2.5 A	1.5 A
			Inductive load (AC-15)	-	1.5 A	0.75 A
		DC	Resistive load (DC-12)	2.5 A	1.1 A	0.55 A
Inductive load (DC-13)	2.3 A		0.55 A	0.27 A		
Electric shock protection class		Class II (IEC 61140),  (double insulated)				
Protection		IP67 (IEC 60529)				
Shock resistance		Malfunction: 300 m/s ² Destruction: 1,000 m/s ²				
Vibration resistance		Malfunction: 5 to 55 Hz, half amplitude 0.5 mm 0.020 in Destruction: 30 Hz, half amplitude 1.5 mm 0.059 in				
Operating frequency		1,200 operations/hour				
Actuator operating speed		0.05 to 1.0 m/sec.				
B10d		2,000,000 (ISO 13849-1 Annex C Table C.1)				
Mechanical durability		1,000,000 operations min. (GS-ET-15)				
Electrical durability		100,000 operations min. (AC-12, 250 V 1.5 A, DC-12 250 V 0.2 A) 1,000,000 operations min. (AC/DC 24 V 100 mA) (1,200 operations/hour)				
Direct opening travel		8 mm 0.315 in min.				
Direct opening force		60 N min.				
Contact resistance		300 mΩ max. (initial value, 1 m 3.281 ft cable) 700 mΩ max. (initial value, 5 m 16.404 ft cable)				
Short-circuit protective device		Use 250 V / 10 A fast acting type fuse				
Conditional short-circuit current		50 A (250 V)				
Material		Enclosure: PA66				
Cable		UL style 2464, No.20 AWG 6-core				
Weight		SG-A1-□-1 : Approx. 120 g, SG-A1-□-5 : Approx. 420 g				

- Notes: 1) Basic insulation of 2.5 kV, 1.5 kV impulse withstand voltage is ensured between different contact circuits and between contact circuits and LED or solenoid in the enclosure. When both SELV (safety extra low voltage) or PELV (protective extra low voltage) circuits and other circuits (such as 230 V AC circuits) are used for the solenoid power and contact circuits at the same time, the SELV or PELV requirements are not met any more.
- 2) The actuator locking strength is rated at 500 N of static load. Do not apply a load higher than the rated value.
Do not apply a load higher than the rated value.
When a higher load is expected to work on the actuator, provide an additional system consisting of another safety switch without lock (such as the **SG-A1** safety switch) or a sensor to detect door opening and stop the machine.

PRECAUTIONS FOR PROPER USE

- This catalog is a guide to select a suitable product. Be sure to read the instruction manual attached to the product prior to its use.



- In order to avoid electric shock or fire, turn the power off before installation, removal, wire connection, maintenance, or inspection of the safety switch.
- If relays are used in the circuit between the safety switch and the load, consider the danger and use safety relays, since welding or sticking contacts of standard relays may invalidate the functions of the safety switch.
- Do not place a PLC in the circuit between the safety switch and the load. Safety and security can be endangered in the event of a malfunction of the PLC.
- Do not disassemble or modify the safety switch, otherwise a breakdown or an accident may occur.
- Do not install the actuator in a location where the human body may come in contact. Otherwise injury may occur.
- Magnet lock type is locked when energized, and unlocked when de-energized. When energization is interrupted due to wire disconnection or other failures, the safety switch may be unlocked causing possible danger to the operators. Magnet lock type must not be used in applications where locking is strictly required for safety. Perform a risk assessment and determine whether solenoid lock type is appropriate.

Both series

- Regardless of door types, do not use the safety switch as a door stop. Install a mechanical door stop at the end of the door to protect the safety switch against excessive force.
- Do not apply external force on the actuator while unlocking, otherwise the actuator may not be unlocked.
- Do not apply excessive shock to the safety switch when opening or closing the door. A shock to the safety switch exceeding 1,000 m/s² may cause damage to the safety switch.
- If the operating atmosphere is contaminated, use a protective cover to prevent the entry of foreign objects into the safety switch through the actuator entry slots. Entry of a considerable amount of foreign objects into the safety switch may affect the mechanism of the safety switch and cause a malfunction.
- Do not store the safety switches in a dusty, humid, or organic-gas atmosphere, or in an area subjected to direct sunlight.
- Use proprietary actuators only. When other actuators are used, the safety switch may be damaged.

SG-B1 series

- The locking strength is rated at 500 N. Do not apply a load higher than the rated value. When a higher load is expected, provide an additional system consisting of another safety switch without lock (such as the **SG-A1** safety switch) or a sensor to detect door opening and stop the machine.
- Regardless of door types, do not use the safety switch as a door lock. Install a separate lock using a latch or other measures.
- While the solenoid is energized, the switch temperature rises approximately 35 °C 95 °F above the ambient temperature (to approximately 85 °C 185 °F while the ambient temperature is 50 °C 122 °F). Do not touch to prevent burns. If cables come into contact with the switch, use heat-resistant cables.
- Bouncing will occur on the lock monitor contact during locking and unlocking (reference value: 20 ms).

- Although the **SG-K11 / SG-K12 / SG-K12A** actuators alleviate shock when the actuator enters a slot in the safety switch, make sure that excessive shock is not applied. If the rubber bushings become deformed or cracked, replace with new ones.

SG-A1 series

- Cover the unused actuator entry slot using the slot plug supplied with the safety switch.

Minimum radius of hinged door

- When using the safety switch on hinged doors, refer to the minimum radius of doors shown below. When using on doors with small minimum radius, use the angle adjustable actuator (**SG-K13 / SG-K14**).

Note: The values indicated in the figures below assume that there is no mechanical interference between the actuator and the safety switch when the door is opened or closed. Because deviation or dislocation of hinged doors may occur in actual applications, make sure of the correct operation before installation.

When using the right-angle actuator (SG-K12 / SG-K12A)

SG-B1 series

<When the door hinge is on the extension line of the actuator mounting surface>

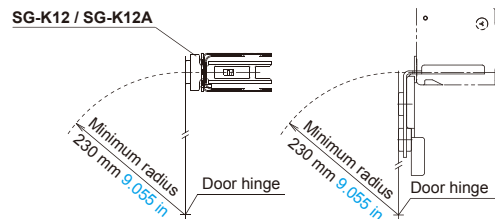

<When the door hinge is on the extension line of the safety switch surface>

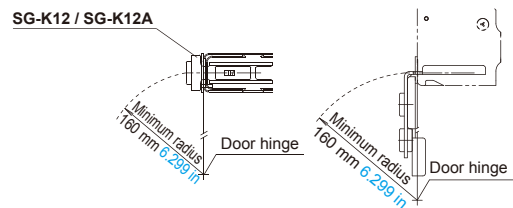

SG-A1 series

<When the door hinge is on the extension line of the actuator mounting surface>

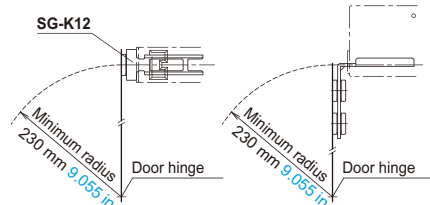

<When the door hinge is on the extension line of the safety switch surface>

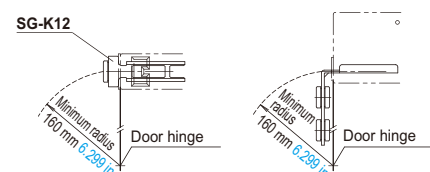

PRECAUTIONS FOR PROPER USE

When using the (SG-K13 / SG-K14) angle adjustable (vertical / horizontal) actuator

- When the door hinge is on the extension line of the actuator mounting surface: 70 mm 2.756 in
- When the door hinge is on the extension line of the safety switch surface: 50 mm 1.969 in

SG-B1 series

<When the door hinge is on the extension line of the actuator mounting surface>

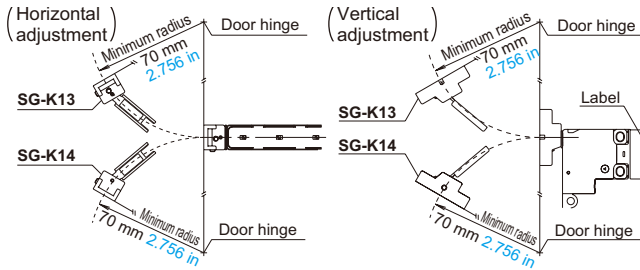

<When the door hinge is on the extension line of the safety switch surface>

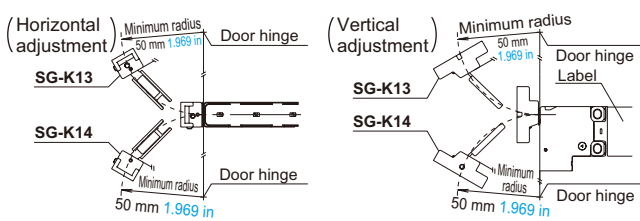

SG-A1 series

<When the door hinge is on the extension line of the actuator mounting surface>

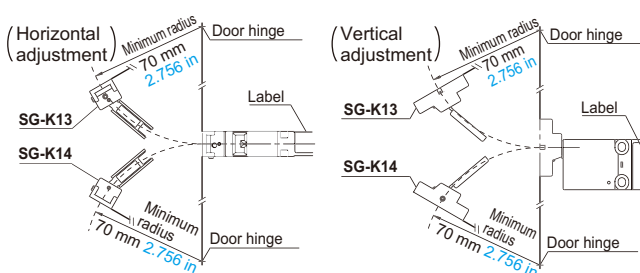

<When the door hinge is on the extension line of the safety switch surface>

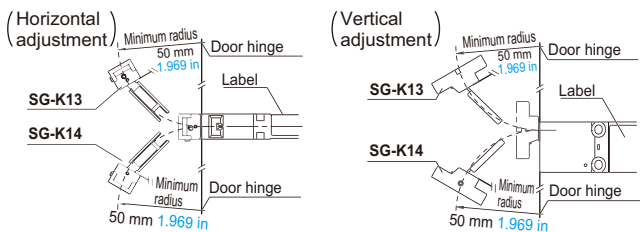



Actuator angle adjustment (vertical / horizontal)

- Using the angle adjustment screw (M3 hexagon-socket-head screw), the actuator angle can be adjusted. Adjustable angle: 0 to 20°
- The larger the adjusted angle of the actuator, the smaller the applicable radius of the door opening. After installing the actuator, open the door. Then adjust the actuator so that its edge can be inserted properly into the actuator entry slot of the safety switch.
- After adjusting the actuator angle, apply Loctite to the adjustment screw so that the screw will not move.

Mounting

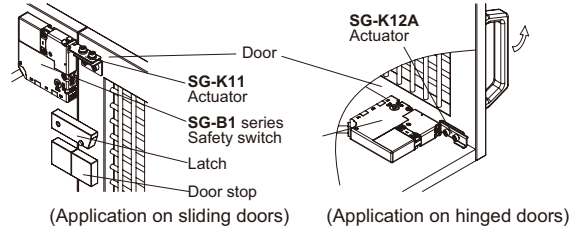
- Mount the safety switch on a fixed piece of machinery or guard and the actuator on a hinged door. Avoid mounting both the safety switch and actuator on a hinged door. Doing so may cause equipment failure. For more information about how to mount the devices, see the following diagram:



Note: When mounting the actuator, make sure that the actuator  enters the slot in the correct direction, as shown on the right figure.

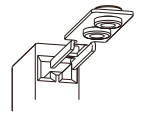

Recommended tightening torque for mounting screws

Safety switch: 1.0 to 1.5 N·m (Three M4 screws)*

Actuator: 1.0 to 1.5 N·m (Two M4 screws)*

- *The above recommended tightening torques of the mounting screws are the values confirmed with hexagon-socket-head bolts. When other screws are used and tightened to a smaller torque, make sure that the screws do not become loose after mounting.
- Mounting bolts must be provided by the users.
- To avoid unauthorized or unintended removal of the safety switch and the actuator, it is recommended that the safety switch and actuator are installed in a secure manner, for example using special screws or welding the screws.
- When installing the **SG-K12A** actuator, use the mounting plate (supplied with the actuator) on the hinged door, and mount tightly using two M4 screws.

The mounting plate has orientation.

Do not lose the mounting plate.

Adequate performance cannot be

obtained without the plate as the

actuator may fall off the door.

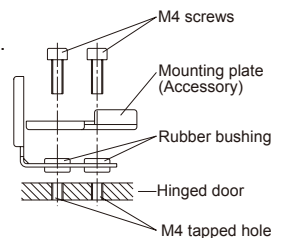

Cables

- Do not fasten or loosen the gland at the bottom of the safety switch.
- When bending the cable during wiring, make sure that the cable radius is kept at 30 mm 1.181 in minimum.
- When wiring, make sure that water or oil does not enter the cable.
- The solenoid has polarity. Make sure of the correct polarity when wiring.

SG-B1 series

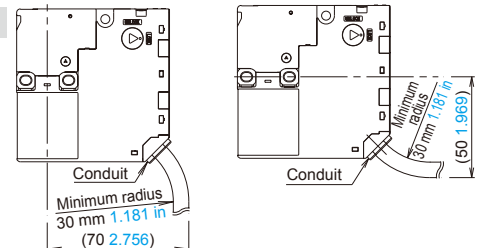

SG-A1 series

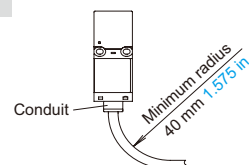

(Unit: mm in)

DIMENSIONS (Unit: mm in)

The CAD data in the dimensions can be downloaded from our website.

SG-B1

Safety door switch with solenoid interlock

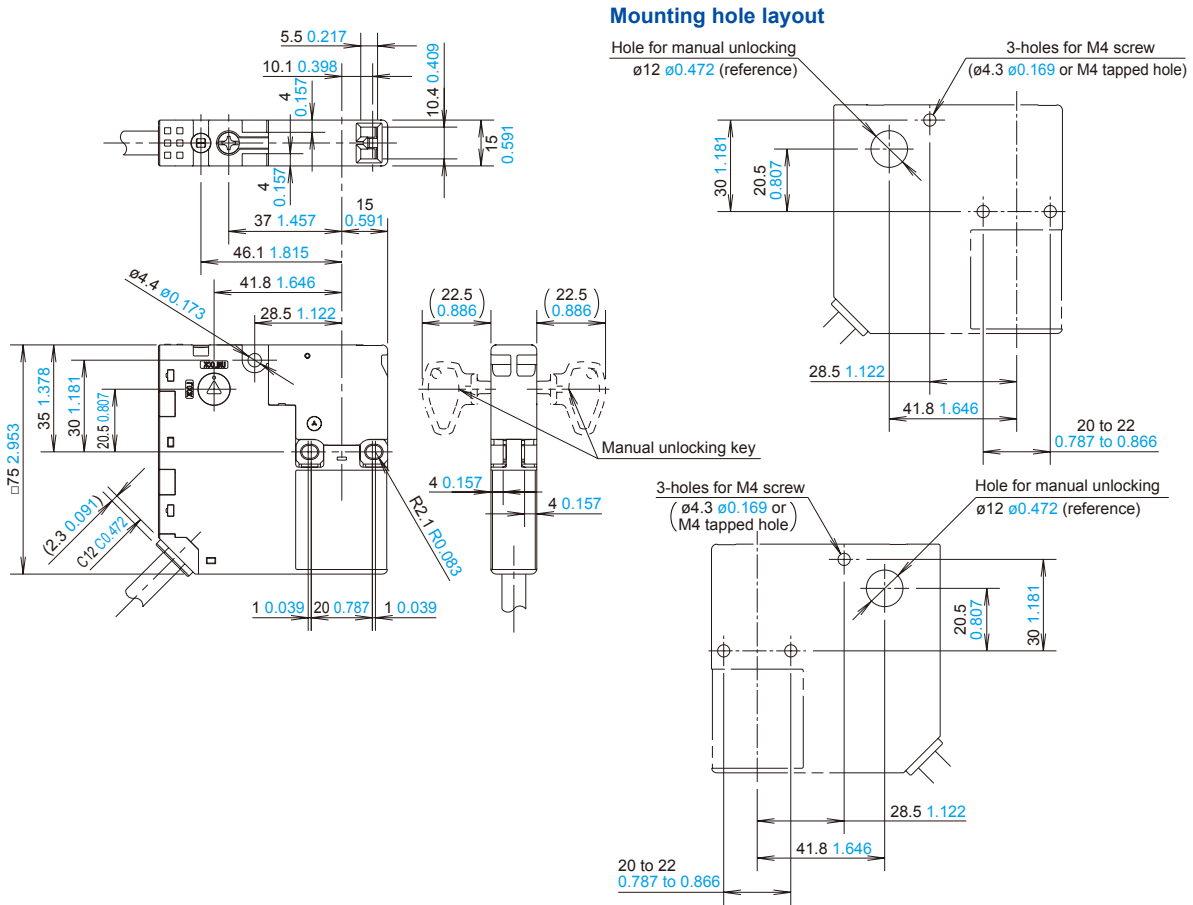

Note 1: Drill mounting holes so that they are properly aligned for the orientation in which the safety switch will be used.

When using straight actuator (SG-K11)

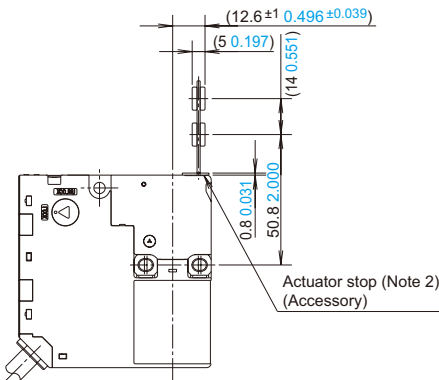

When using the right-angle actuator (SG-K12 / SG-K12A)

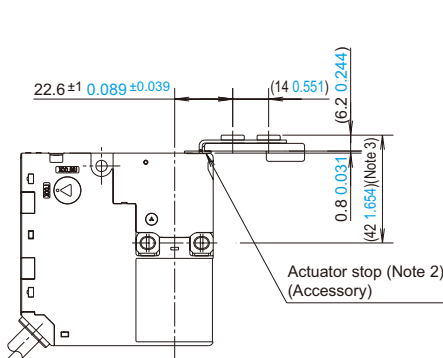

When using the angle adjustable actuator (horizontal / vertical) (SG-K13 / SG-K14)

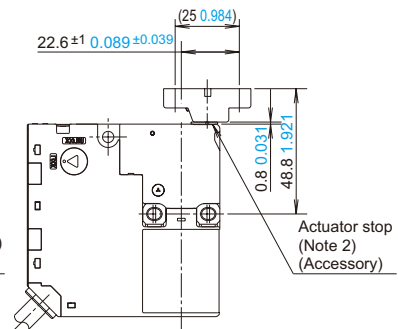

Notes: 2) The actuator stop is used to adjust the actuator position. Remove the actuator stop after the actuator position is mounted.

3) 41.4 1.63 when using **SG-K12**

* The tensile strength of the **SG-K12** actuator is 100N. If an excessive tensile force is applied, the actuator may fall off the door. When a tensile force exceeding 100N is expected, use the **SG-K12A** actuator with a plate.

Actuator mounting reference position

As shown in the figure on the right, the mounting reference position of the actuator when inserted in the safety switch is:

The actuator stop on the actuator lightly touches the safety switch.

* The actuator stop is used to adjust the actuator position. Remove the actuator stop after the actuator position is mounted.

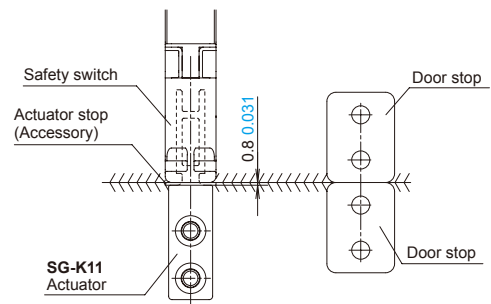

DIMENSIONS (Unit: mm in)

The CAD data in the dimensions can be downloaded from our website.

SG-A1 Safety door switch

Mounting hole layout

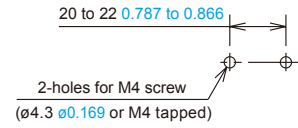
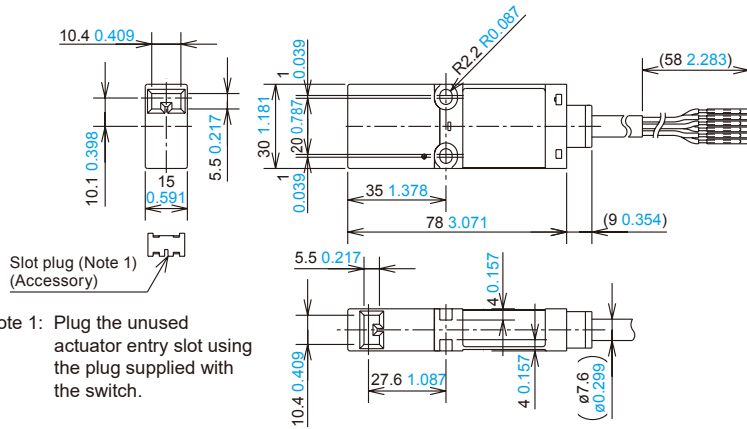

*The safety switch can be mounted in two directions.

Note 1: Plug the unused actuator entry slot using the plug supplied with the switch.

When using straight actuator (SG-K11)

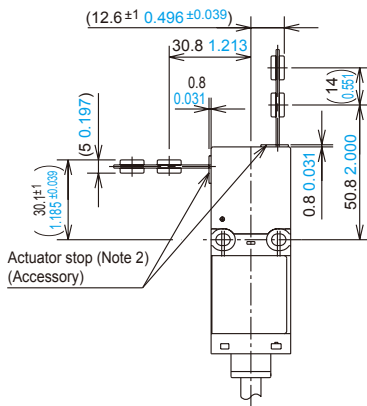

When using the right-angle actuator (SG-K12)

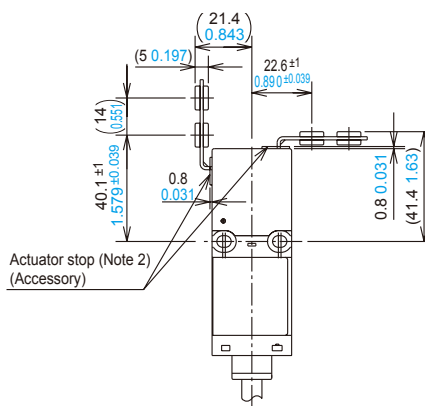

When using the angle adjustable actuator (horizontal / vertical) (SG-K13 / SG-K14)

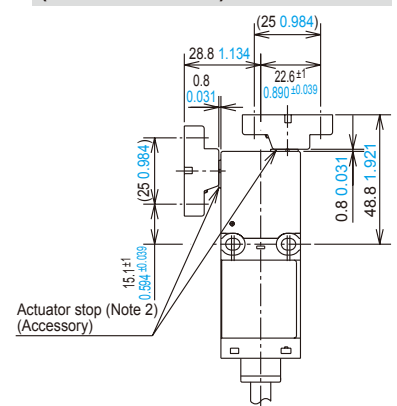

Note 2: The actuator stop is used to adjust the actuator position. Remove the actuator stop after the actuator position is mounted.

SG-K11 / SG-K12 Actuator

Straight actuator (SG-K11)

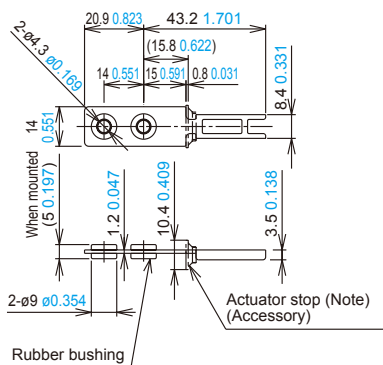

Right-angle actuator (SG-K12)

* The tensile strength of the **SG-K12** actuator is 100N. If an excessive tensile force is applied, the actuator may fall off the door. When a tensile force exceeding 100N is expected, use the **SG-K12A** actuator with a plate.

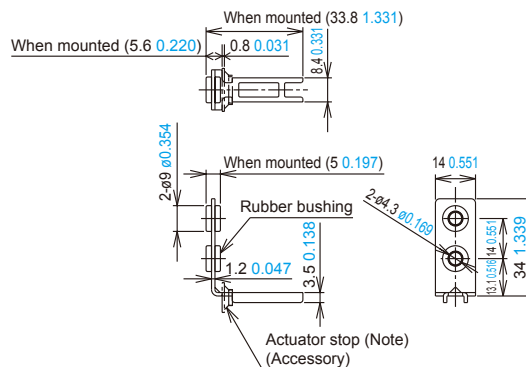

Note: The actuator stop is used to adjust the actuator position. Remove the actuator stop after the actuator position is mounted.

Actuator mounting hole layout (Straight actuator, right-angle actuator)

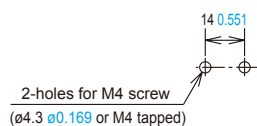

DIMENSIONS (Unit: mm in)

The CAD data in the dimensions can be downloaded from our website.

SG-K13 / SG-K14

Actuator

Horizontal / vertical angle adjustable actuators (SG-K13)

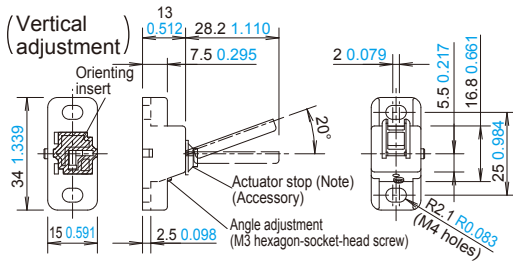
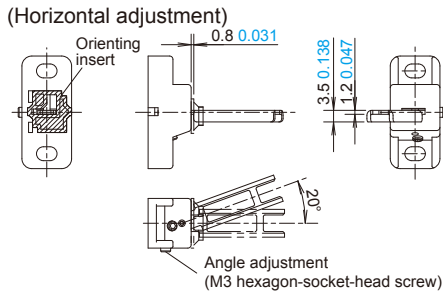

Horizontal / vertical angle adjustable actuators (SG-K14)

* The **SG-K14** differs from the **SG-K13** in that the direction in which the metal parts on the tip of the actuator are embedded is reversed by 180°.

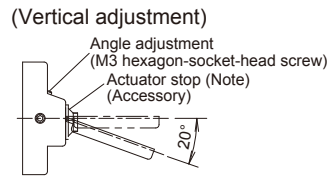
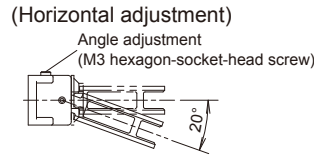

Changes in the orientation of adjustment for angle adjustable (horizontal / vertical) actuators

The orientation of actuator adjustment (horizontal / vertical) can be changed using the orienting insert (white plastic) installed on the back of the actuator. Do not lose the mounting plate.

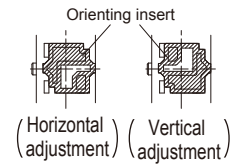

* The base is made of glass-reinforced PA66 (66 nylon). Angle adjustment screws are stainless steel (SUS).

When using adhesive on screws, take material compatibility into consideration.

Note: The actuator stop is used to adjust the actuator position. Remove the actuator stop after the actuator position is mounted.

Actuator mounting hole layout (horizontal / vertical angle adjustable actuators)

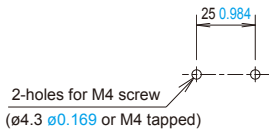

Manual unlocking key (Accessory: plastic)

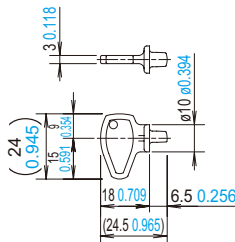

Disclaimer

The applications described in the catalog are all intended for examples only. The purchase of our products described in the catalog shall not be regarded as granting of a license to use our products in the described applications. We do NOT warrant that we have obtained some intellectual properties, such as patent rights, with respect to such applications, or that the described applications may not infringe any intellectual property rights, such as patent rights, of a third party.

Panasonic
INDUSTRY

Panasonic Industry Co., Ltd.

Industrial Device Business Division
7-1-1, Morofuku, Daito-shi, Osaka 574-0044, Japan
industry.panasonic.com